

E-Mon D-Mon

Energy Monitoring Products & Systems

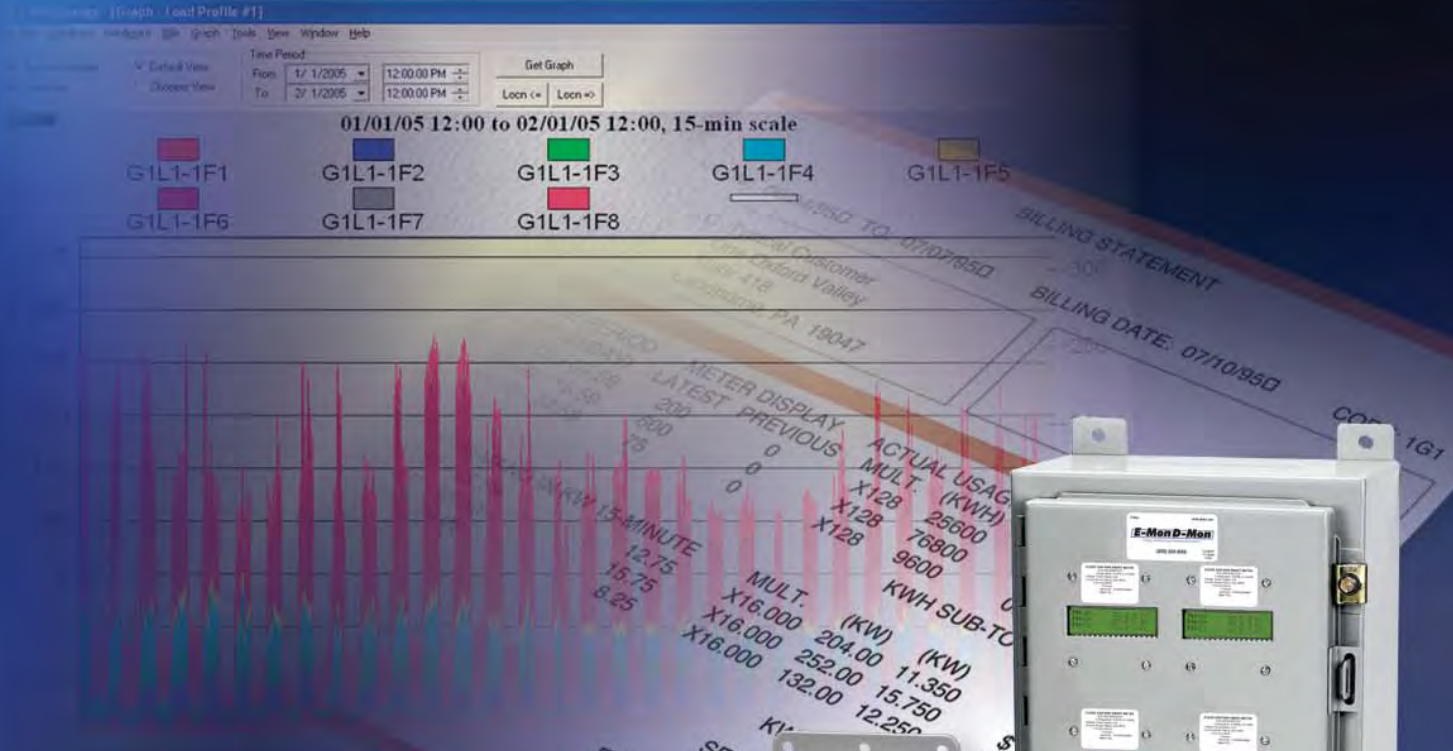

(800) 334-3666
www.emon.com

Why Submeter?		Page
	<i>Monitoring Electrical Usage, Submeters At A Glance</i>	1
	<i>Energy Analysis, Energy Conservation/Green Buildings</i>	2
	<i>Cost Allocation, Tenant Billing, Integration with Building Management/Automation Systems</i>	3
Submetering Applications		
	<i>Commercial - Office & Retail, Multi-Family Residential, Healthcare & Hospitals</i>	4
	<i>Industrial/Manufacturing, Educational</i>	5
	<i>Government</i>	6
National, State & Local Approvals		6
Sample Submetering Customer List		7-8
Metering Products & Systems		
Product Overview		
	Standard Meters & Green Class Meters	9
	Smart Meters & Multi-Mon	10
	Power Quality Meters & Other Gas, Water, Steam, Electric Meters	11
Standard Metering Products		
	Class 1000 Single-Phase Meter Specifications	12
	Class 2000 Three-Phase kWh/Demand Meter Specifications	13
Green Class Meters		
	Green Class Meter Specifications	14
	Green Class Net Meter Specifications	15
Smart Metering Products		
	Class 3200 Smart Meter Specifications	16
	Class 3400 Smart Meter Specifications	17
	Class 5000 Smart Meter Specifications	18
	Din-Mon D2 Smart Meter for BAS Integration	19
	Din-Mon D5 Smart Meter for BAS Integration	20
	Multi-Mon Multiple Branch Circuit Monitor	21
Power Quality Metering Products		
	PowerSmart+ Essential	22
	PowerSmart+ Advanced	23
	PowerSmart+ Socket	24
	<i>Third Party Metering Products (gas, water, steam, BTU, electric, etc.)</i>	25
Current Sensors		
	<i>E-Mon D-Mon Split-Core Current Sensor Specifications</i>	26
	<i>Din-Mon Current Sensor Specifications</i>	27
	<i>Multi-Mon & PowerSmart+ Current Sensors</i>	28
Metering Systems		
Product/System Overview		
	E-Mon Energy Automatic Meter Reading System	29
	Web-Mon Web-Enabled Energy Monitoring System	30
	Integration with Other Building Management/AMR Systems	30
Product/System Specifications		
	E-Mon Energy System	
	E-Mon Energy Software - Single License & Server Version	31
	E-Mon Energy Sample Energy Graph & Billing Statement	32
	IDR Interval Data Recorder	33
	System Configuration	34
	Web-Mon Web Enabled Energy Monitoring System	
	Web-Mon Specifications	35
	Web-Mon Sample Energy Dashboards	36
	Web-Mon System Configuration	36
	E-Mon Meter Reading, Installation & Billing Services	37
	Attune Energy Dashboard Service	38
Reference Guides		
	E-Mon D-Mon Meter Installation Overview	39
	Meter Enclosure Specifications	40
	MMU Enclosure Specifications	41
	Modbus Point Map Sample	42
	BACnet Object Descriptor Sample	43
	BACnet PIC Statement Sample	44
	LonWorks SNVT Sample	45

Why Submeter?

Rising energy costs continue to pressure operators of commercial, industrial, institutional and multi-family residential facilities to leave “no stone unturned” in finding ways to reduce operating expenses. Users have turned to submetering to identify when and where energy is used in order to implement energy conservation measures and programs.

Monitoring Electrical Usage

E-Mon, the industry leader in submetering hardware and software, responded to the growing need for more sophisticated energy profiling by developing advanced metering products that provide usage data beyond the master utility meter. Used in conjunction with automatic meter reading (AMR) software, submetering systems provide accurate and timely snapshots of a facility’s energy use — from a single circuit or device all the way up to an entire building and beyond. Essential to support energy management initiatives, submeter-based AMR systems combine all of the facility’s utility service data — electric, water, gas, steam and others — into a single, easy-to-use system to show exactly how, when and where the facility is using energy.

First introduced in the early 1980’s E-Mon D-Mon electric submeters are installed on the facility side of the master utility meter to provide a number of energy monitoring functions including:

- Electrical usage analysis and identification of peak demand levels for load comparisons
- Time-of-use metering of electricity, gas, water, steam, BTUs and other energy sources
- Fair and equitable cost allocation for tenant billing
- Measurement, verification and benchmarking of kW/kWh for energy and green building initiatives
- Net Metering

Submeters At A Glance

Of the three main submeter types shown in the table below, the first two feed-through and current transformer (CT) based are socket type meters. CT-style socket meters are used with loads of 400A and above. In commercial applications, they may be specified but will take up a lot of space in the electrical room due to the need for CT cabinets and meter bases. The extra space requirements cut into the available rental space, which is undesirable in the commercial marketplace. Another major disadvantage in many jurisdictions is that socket meters are not UL listed. The third type is the electronic submeter, such as the E-Mon D-Mon a non-socket device that provides clear advantages over the previous two.

	SUBMETER TYPE		
	Socket Type Electromechanical/Solid State		E-Mon D-Mon Electronic
	Feed-Thru Type	Current Transformer Type	Non-Socket Type
INSTALLATION			
Installed Cost (Estimated)			
Stand Alone, up to 3200A, 3Ø	\$1,000	Not Applicable	\$700
Stand alone, over 3200A 3Ø	Not Applicable	\$2000-\$5000	\$800
8-meter Unit, 200A 3Ø	\$16,000	Not Applicable	\$5,500
Installation Time	2-3 hours	6-8 hours	1 hour
Power Interruption	2-3 hours	6-8 hours	None
Amperage Limitations	320 Amp Max.	None	None
Space Requirements	2 Square Ft	11.7 Square Ft	0.25 Square Ft
Installation Location	Utility Room	Utility Room	Anywhere
FEATURES			
Multiple Meter Units (MMU)	Yes	Yes	Yes
Size of 8-unit Cabinet	18.1 Square Ft	18.1 Square Ft	2 Square Ft
Digital Readouts	Optional/Yes	Optional/Yes	Standard
Reset Capabilities	No/Yes	No/Yes	Standard
Multiple Load Monitoring	No	No	Yes
Subtractive Load Monitoring	No	No	Yes
Monitor Specific In-Panel Circuits	No	No	Yes
Amperage Modification In Field	No	w/CT Change	Yes
Meter UL Listed	No	No	Yes
ENHANCEMENTS			
Pulse Outputs	Yes	Yes	Yes
Software Monitoring	Yes	Yes	Yes
Upgradeable in the Field	No	No	Yes
Power Quality Functions	Available	Available	Yes
Net-Metering Capability	Yes	Yes	Yes
Form C Control Relay Output	No	No	Yes

Why Submeter?

Energy Analysis

The type of energy data needed by today's sophisticated facility manager is well beyond the capability of the master utility meter at the main service entrance. Master meters provide a broad indication of consumption and demand, but true load profiling requires specific interval usage data from key loads to isolate the causes of load peaks as a first step to eliminating them or moving them to off-peak hours when rates are lower.

As first-level data gathering tools in the facility load profiling process, submeters provide high-accuracy interval data snapshots of energy use and demand from enterprise level all the way down to a specific circuit or item of equipment. The use of meters and submetering systems provide energy information necessary for:

- Load Profiling & Benchmarking
- Measurement & Verification
- Usage Aggregation
- BAS Integration
- Power Quality Analysis

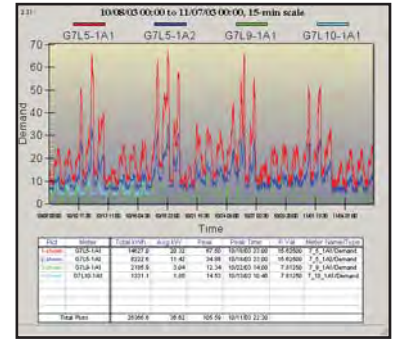

E-Mon's line of submetering hardware and software systems are designed to provide accurate energy profile data for use in cutting costs, using energy resources more efficiently and improving your facility's bottom line.

Energy Conservation/Green Building Initiatives

With world focus on green building sustainability, submeters offer environmentally conscious users the ability to establish benchmark energy usage data, monitor usage trends, record the impact of energy conservation efforts and measure & verify the ongoing effectiveness of energy saving programs.

Meters and submetering systems are ideal for complying with various programs including LEED, EPACT 2005 & EISA 2007, demand response and renewable energy initiatives.

The country's leading sustainable building assessment system is currently the U.S. Green Building Council's Leadership in Energy & Environmental Design (LEED) rating system. E-Mon can assist with LEED certification points in several areas including M & V, fundamental commissioning, on-site renewable energy, green power and regional material. Of the system's nine categories, the left hand column below lists those areas prime for submetering applications, including Water Efficiency (WE) and Energy & Atmosphere (EA) credits.

NEW LEED v4 Water Efficiency (WE) and Energy & Atmosphere (EA) Prerequisites & Credits Requiring Meter Use				
LEED v4 Rating System	Impacts	Type / Points	Description	Comments
Building Design & Construction (BD+C)	<ul style="list-style-type: none"> • New Construction (NC) • Core & Shell (CS) • Schools • Retail • Data Centers • Warehouse & Distribution Centers • Hospitality • Healthcare • Homes & Multifamily Lowrise • Multifamily Midrise 	WE Prerequisite	Outdoor Water Use Reduction	Reduction in landscape water use by 30%
		WE Prerequisite	Building-level Water Metering	Permanently installed metering to measure potable water use; agree to share data with USGBC for 5 years
		WE Credit	Water Metering	Rewards submetering of at least two water subsystems; e.g., irrigation, domestic hot water, reclaimed water, etc.
		WE Credit	Cooling Tower Water Use	Projects encouraged to analyze water source and maximize water cycles
		EA Prerequisite	Building-level Energy Metering	Install metering to aggregate total facility energy use, viz., kWh, kW, gas, steam, BTU, etc.; agree to share data with USGBC for 5 years
		EA Prerequisite	Energy Metering	Multifamily projects must meter or submeter each unit
		EA Credit	Advanced Energy Metering	Permanently installed meters with 60-min interval data recording of kWh/kW; 36-m min data storage; remote / LAN communications to BAS for all energy sources at 10% or more of total energy use.
Building Operations & Maintenance (O+M)	<ul style="list-style-type: none"> • Existing Buildings • Schools • Retail • Data Centers • Hospitality • Warehouses & Distribution Centers 	WE Prerequisite	Building-level Water Metering	Permanently installed metering to measure potable water use; agree to share data with USGBC for 5 years; 1-2 water subsystem meter credits also possible
		EA Prerequisite	Building-level Energy Metering	Install metering to aggregate total facility energy use, viz., kWh, kW, gas, steam, BTU, etc.; monthly/annual summaries; agree to share data with USGBC for 5 years
		EA Credit	Advanced Energy Metering	Combines 2 previous criteria from LEED v3; permanently installed meters with 60-min interval data recording of kWh/kW; 36-m min data storage; remote/LAN communications to BAS; applies to any whole bldg. system of 20% or more total energy use.
		EA Credit 1-3	Demand Response	Install interval data recorders & other infrastructure for future DR program participation (1 pt) or actively participate in existing DR program (3 pts)
Interior Design & Construction (ID+C)	<ul style="list-style-type: none"> • Commercial Interiors (CI) • Retail • Hospitality 	EA Credit 1-2	Advanced Energy Metering	Tenant-level, whole facility metering with 1-mo interval data (1 pt); or permanently installed meters with 60-min interval data recording of kWh/kW; 18-m min data storage; remote LAN communications to BAS; applies to any end use drawing 10% or more of total energy use

Source: LEED v4 User Guide, October 2013

EPACT 2005/EISA 2007 Compliance	
Section 102	Reduce gross square foot energy consumption by 20% by 2015
Section 103	All federal buildings must be metered by 2012
Section 1251	Net Metering
Section 1331	Support for \$1.80 federal tax deduction
EISA Title IV, Sec. 434	Provide equivalent metering of gas and steam by 2016

Why Submeter?

Building owners and facility managers are faced with ever increasing utility costs that eat away at the bottom line. In order to begin managing these costs, users need to know where the energy is being used and be able to allocate the costs appropriately. Submetering products and systems allow users to see specifically where and when energy is consumed within the building envelope. Meters are used to monitor actual usage by department, tenant or common area and report back to computerized systems for billing, allocation, analysis and management.

Cost Allocation

Metering individual departments, areas or buildings for cost center analysis, budgetary accountability and allocation allows visibility into energy consumption and usage trends. Armed with this critical information, managers are able to take advantage of energy savings opportunities that may be as simple as turning off lights or computers when rooms are not in use. When department budgets include energy consumption, users will be inclined to take the necessary steps to ease the pressure on their budgets by reducing overall energy use.

Meter Billing Statement					
Customer Info			Meter Info		
Customer No.	00000001	1-4-11	Meter No.	00000001	1-4-11
Billing Date	4/12/2004		Billing Date	4/12/2004	
Doc Date	4/21/2004		Doc Date	4/21/2004	
Memo	\$100.00		Memo	\$100.00	
Energy Use					
Time Period	04/01/04	04/30/04	Actual	0.0000	0.0000
Use Period	04/01/04	04/30/04	0.0000	0.0000	0.0000
Int. Peak	300	750	430	0.021000	0.99
On Peak	980	827	847	0.010000	1.67
				Sub-Total	\$32.50
Demand Charge					
Time Period	Peak	Actual	Rate	Usage	Charge
On Peak	02/00/04 12:00	79.50	17.40	1.1000	19.32
Int. Peak	02/00/04 11:00	16.00	16.00	2.0000	36.30
On Peak	02/00/04 13:00	16.00	16.00	2.0000	36.30
Commercial	0.00	0.00	0.0000	0.00	0.00
Distribution Demand	0.00	0.00	0.0000	0.00	0.00
				Sub-Total	\$108.72
Other Charges					
Item	Rate	Usage	Charge		
Rate Adjustment 1	1772.0000	0.00165	2.92		
Rate Adjustment 2	1772.0000	0.00070	1.24		
	1772	0.00000	0.00		
	1772	0.00000	0.00		
	1772	0.00000	0.00		
	1772	0.00000	0.00		

Tenant Billing



In facilities where there are multiple tenants, monitoring actual consumption is a win-win situation for both the building manager and the tenants.

Managers are able to allocate energy usage costs directly to the tenants. Energy costs can include not only electric, but gas, water and BTU costs as well. In addition, all common area usage can be monitored and distributed equitably between tenants. Both tenant billing and common area allocation allows building managers to recoup energy expenses.

Tenants benefit from submetering of actual energy usage in two ways. First, tenants only pay for what they use. They are not burdened with the overflow cost of large users as they would be if billed a flat rate per square foot of space rented. The second benefit is that they gain control over their usage allowing them to conserve energy and benefit financially for their efforts.

Whether metering a commercial or residential tenant, department or common area, cost allocation and accurate billing practices help reduce costs, recoup energy expenses and promote energy conservation.

Integrate with Building Management/Automation Systems

A key element of today's sustainable building management system (BAS/BMS) is providing timely, accurate and detailed energy data for advanced analysis and reporting of energy and environmental conditions within the facility. Submeters play an integral role in providing granular interval energy data to building automation systems to facilitate important energy decisions.

Energy data is acquired and stored by the submeters and transmitted to the central monitoring system through industry standard protocols including BACnet, Modbus, LonWorks and EZ-7. E-Mon D-Mon smart meters communicate through two protocols simultaneously allowing users the advanced capability of running energy data to a billing system like E-Mon Energy and a BAS system at the same time with one metering device.

Accurate and timely raw interval energy data can be presented through charts, graphs or utility statements through the BAS, local or remote PC or via the Web. With detailed data and presentation options, users are able to effectively monitor and control usage and processes in their building.



Submetering Applications

Commercial - Office & Retail

In today's commercial office, retail and mixed-use facility environments, you'll find submeter-based energy monitoring solutions from E-Mon benefiting parties on both sides of the electric bill. At the enterprise level, submeters help facility managers track everything from common area usage and HVAC system performance to monitoring after-hours energy usage for recovering and allocating costs back to the using tenant.

From the tenant's perspective, submeters eliminate problems associated with arbitrary ratio-based measures like square-footage that favor high-volume users over low use tenants. Tenants are also able to benefit financially from any energy conservation practices they implement.

Submeters provide the usage data that allows managers to generate electric bills that put tenant fairness concerns to rest by including proof of exact use with every billing statement.

In addition, E-Mon hardware and software solutions were specifically designed to:

- Allocate energy costs to specific lease spaces, circuits or buildings
- Profile entire facility data for demand management, load shedding & energy initiative compliance
- Aggregate energy demand/use for bulk energy contracts
- Implement demand response/control to avoid costly demand charges



Multi-Family Residential



Rising energy rates are driving multi-family property owners to allocate utility costs back to tenants, recover revenue and promote resource conservation. Arbitrary square-footage cost allocation and other ratio billing measures do little to encourage energy conservation. Alternatively, tenants in high-rises, condos, co-ops and mixed-use buildings have been shown to use up to 25% less energy when submeters hold them accountable for the power they use.

In high-rise applications, managers and owners from all multi-family type dwellings are turning to E-Mon to track and unbundle utility costs from their leases and association fees; a property value enhancing capability in many jurisdictions.

Ideal for new or retrofit applications, E-Mon's versatile metering solutions offer a range of capabilities from "walk up and read" to complete AMR (Automatic Meter Reading) solutions that can incorporate all utilities including gas and water into one easy-to-use system.

Ideally suited for any multi-family residential application, E-Mon's complete selection of metering hardware and software is the perfect cost-effective solution for tenant metering and common area allocation.

Healthcare & Hospitals

The increasing costs of energy impacts healthcare facilities whether they are large hospitals or small medical offices. DOE's analysis of energy use in the healthcare sector, in which \$5.3 billion is spent every year, is second only to the food service industry in terms of consumption.

Because of their unique energy requirements these types of facilities face a growing challenge in managing and controlling their energy use and demand without negatively impacting the quality and cost of their services. As the tool for measuring and verifying the facility's energy footprint, submetering hardware and software are an easily installed, readily available Rx for that old energy adage that says "You can't manage what you don't measure."



Some specific uses for submeters in the healthcare environment include:

- Analysis, measurement, verification & benchmarking of peak demand (kW) & consumption (kWh) for compliance with energy initiatives.
- Time-of-use metering of electricity, gas, water, steam, BTUs and other energy sources.
- Load comparisons and usage monitoring.
- Cost allocation of actual usage to specific users, tenants and departments within the facility.

Industrial/Manufacturing



With the industrial sector consuming more than one-third of all U.S. energy, it's easy to see why facility managers are seeking ways to reduce energy costs without compromising production. E-Mon's advanced metering hardware, communication options and E-MonEnergy™ software can help personnel zero in on the real costs and investments in their industrial processes.

As part of the facility energy picture, plant operators need accurate, real-time energy data to evaluate the performance of individual processes, pieces of equipment and departments. In any type of industrial facility, whether process or discrete manufacturing, E-Mon D-Mon submeters are an extremely cost-effective way to chart energy usage, isolate specific processes that are not energy efficient and provide real-time evaluation of critical load-shedding activities.

Submeters allow electric, water, gas, steam, BTUs and other parameters to be easily factored into the facility energy profile for

management. In addition to identifying poor performers by benchmarking energy levels at multiple facilities, submeters can also be used to help identify other energy saving opportunities.

Metering opportunities include:

- Cost allocation - Allocate costs to offices and departments to identify administrative costs vs. production costs, or allocate costs to production lines, production runs and individual and/or groups of equipment.
- Energy Analysis - Monitor and identify "high use" pieces of equipment for load shedding/shifting programs or to identify maintenance issues for repair before critical equipment fails.

Educational

With today's schools and universities facing mounting financial pressure, controlling the bottom line is key to maintaining current programs and keeping education affordable. However, in spite of tightening budgets, energy conservation and cost reduction are realistic goals that any district or educational facility can achieve using E-Mon D-Mon submetering products.

Designed to install easily in new or retrofit applications, cost-effective E-Mon D-Mon meters are ideal for departmental budget allocation, identifying peak energy inefficiencies, common area lighting and event metering. Student housing is a prime candidate for submetering. Submetering dorm rooms, suites or buildings allows billing according to actual usage. Installing Green Class meters or Web-Mon displays in public areas allows students to immediately see the impact of their conservation efforts.

Other applications on campus include coffee shops, food service, bookstores and various retail spaces that use energy at different rates. Submeters are ideal for monitoring and generating accurate and fair energy statements based on individual use. Key equipment can also be metered to profile energy use, allowing facility engineers to reduce downtime by diagnosing costly failures before they happen. In addition, analysis of energy load trends highlight opportunities to shift energy loads to off-peak hours or stagger loads to reduce costly demand charges.

Metering opportunities include:

- Student Housing & Dormitory Monitoring
- Departmental Allocation/Budgeting
- Leased Spaces
- Event Allocation
- Equipment Maintenance



Submetering Applications

Government

As the nation's single largest energy user and a significant consumer in many areas of the country, federal and local governments are keenly aware of the need to not only conserve energy, but to invest in the reduction measures that make good business sense while, at the same time, contributing to operational efficiency and modernization. To achieve this goal, the Government established the "Energy Policy Act of 2005 (EPACT) to give guidance in achieving fully managed electrical systems.

"In accordance with guidelines established by the Secretary under paragraph (2), all Federal buildings shall, for the purpose of efficient use of energy and reduction in the cost of electricity used in such buildings, be metered."

Compliance with EPACT 2005 and EISA 2007 regulations and green building initiatives are particularly challenging for government facilities as each complex is unique. These complexes run the full range of building types; office, single and multi-family, plant/industrial, medical and educational. For over 25 years, agencies like DOE, GSA, DOD, VA, Postal Service and Homeland Security have employed advanced meters and submetering systems to measure entire buildings, individual tenants or areas, specific pieces of equipment or individual circuits quickly and accurately.

Metering applications include:

- Whole Building Metering
- Departmental/Tenant Cost Allocation
- Measurement & Verification
- Energy Management & Analysis
- Building Automation System Integration

Some requirements for government facilities included in EPACT and EISA include:

EPACT 2005/EISA 2007 COMPLIANCE

Section 102	Reduce gross square foot energy consumption by 20% by 2015
Section 103	All federal buildings must be metered
Section 1251	Net Metering
Section 1331	Support for \$1.80 federal tax deduction
Title IV, Sec. 434	Provide equivalent metering of gas and steam by 2016



E-Mon D-Mon National, State & Local Approvals

Many E-Mon D-Mon products have been tested and approved by independent testing agencies including:

NATIONAL APPROVALS

- UL/CUL Listed
- CSA Approved (Canadian Standards Assoc.)
- ANSI C12.20 Certified (National Accuracy Standards) by Independent Test Lab (+/- 0.2% from 1% to 100% of rated load.)

STATE & LOCAL APPROVALS

- CA - California Bureau of Weights & Measures, DWP-Los Angeles, CSE-Westminster, SDG&E-San Diego
- CO - Public Service of Colorado - Denver
- FL - Tampa Electric - Tampa
- MI - Detroit Edison - Detroit
- NJ - NJ Dept. of Energy - Newark, PSE&G Approved for DSM program
- NH - New Hampshire Electric Co. - Plymouth
- NY - NYC Approved for RSP Program, City of NY - Bureau of Electrical Control, ConEd Approved for RSP
- PA - PECO Energy - Berwyn
- SC - State of South Carolina - Columbia
- VA - Appalachian Power Company - Roanoke
- PR - PREPA Approved - Puerto Rico

Sample E-Mon D-Mon Customer List by Building Type

Office Buildings

- Canal Place
- Comcast
- CB Richard Ellis
- Crescent Resources
- Cushman & Wakefield
- Edison Properties
- Fed Ex
- Richland Tower
- RJ Equities
- SJP Properties
- Verizon
- Wall Street Tower
- Wells Fargo

Data Centers/Server Farms

- Exxon/Mobil World Data Center
- Go Daddy
- Redstone Arsenal
- Comerica Michigan
- 365 Main Inc.
- Savvis
- Involta
- Management Science Associates
- Merrill Lynch
- Network Appliance
- FDIC
- Federal Reserve

Malls & Shopping Centers

- CityWalk
- Dole Cannery
- Pier One Imports
- Staples
- Tanforan Mall

Hotels

- Ritz-Carlton Hotel
- W Hotel & Condos
- Westin Hotel

Airports

- BWI Airport
- Hartsfield Airport
- Kauai Airport
- Kansas City International Airport
- LAX Airport
- Philadelphia Airport
- Pittsburgh Airport
- Ronald Reagan Airport
- San Diego International Airport

Industrial

- Bausch & Lomb Co.
- Calsonic
- E.I. Dupont, Inc.
- Goodyear Tire
- JJMAC Woven Products
- Johnson & Johnson
- Lockheed Martin
- Kraft General Foods
- Mannington Mills
- MAP Energy
- Mobil Chemical
- Murphy USA
- Perdue, Inc.
- Pepsi
- Quad Graphics
- Schindler Elevator
- Stow Manufacturing
- Toshiba
- Toyota
- Wheaton Glass Co.

Entertainment Facilities

- Cincinnati Zoo
- Denver Convention Center
- Kansas State Fairgrounds
- Mammoth Mountain Ski Resort
- Mile High Stadium
- Nationals Stadium
- Oklahoma State Fairgrounds
- Philadelphia Zoo
- Ravens Stadium
- San Diego Convention Center
- South Florida Ski Resort
- Universal Studios

Multi-Family Residential

- 311 Reynolds St. Apartments
- Esplanade Place
- Heldrich Plaza
- HUD-St. Aloysius
- HUD-Eco Village
- Merritt River Apartments
- Ocean Club Condos
- Park Plaza Apartments
- Randall Court Apartments
- Ritz Carlton Condominiums
- Surf Song Condos
- Texas Christian University Apartments
- W Hotel & Condominiums
- Western View Apartments
- Westwood Apartments

Large-Scale Residential

- White House
- Vice President's Residence
- Bill Gates House

Sample E-Mon D-Mon Customer List by Building Type

Hospitals/Medical Offices

- Bayscape Medical
- Capital Health Systems
- Cedar Park Medical Center
- Gateway Medical Office Building
- Grand Valley Surgical
- Hacienda Medical Center
- Iowa Medical Center
- Irvine Heritage Medical Plaza
- John Lincoln Hospital
- King Edward Memorial Hospital
- Landmark Healthcare
- Lakepoint Medical
- Mayo Clinic
- North Metro Cancer Center
- Pacific Medical Plaza
- Queens Medical Center
- South Texas Oncology
- Spohn Hospital
- Tripler Army Medical Center
- Tiffin Mercy Medical
- Upper Chesapeake Medical Office Building
- William Beaumont Hospital
- Wooster Outpatient

K-12 Education

- Bethke Elementary School
- Browning Park School
- Iowa Braille School
- Milton High School
- San Diego Schools
- St. Andrews School
- Thompson School District

Government-DOD/Military

- 29 Palms MCB - CA
- Army National Guard - HI
- Buckley Air Force Base - CO
- CNIC/Navy Support Facility - Diego Garcia - Chagos Islands
- Delaware Air Nationals Guard - DE
- Dobbins Air Force Base - GA
- Dover Air Force Base - DE
- Edwards Air Force Base - CA
- Ft. Bragg - NC
- Fort Irwin - CA
- Kadena Air Force Base - Okinawa
- Kirtland Air Force Base - NM
- LA Air Force Base - CA
- Navy - Washington, DC
- Navy Weapons Depot - CA
- Tinker Air Force Base - OK
- Travis Air Force Base - CA
- U.S. Army Corp of Engineers - VA
- USMC Rec Center - CA
- US Navy Building - PA
- US Naval Air Station - PR
- Youngstown Air Reserve Base - OH
- U.S. Army Ft. Hood-TX
- Joint Base Lewis McChord-WA

Colleges/Universities

- Beloit College
- Bucks County Community College
- Burlington County College
- Butler County Community College
- Butte College
- Chaminade University
- Chapman University
- Dallas Theological Seminary
- Grinnell College
- Lackawanna Jr. College
- Muhlenburg College
- Ohio State University
- Onondaga Community College
- Penn State University
- Rockhurst University
- Rutgers University
- Salem College
- Stockton State University
- SUNY-Stonybrook
- SUNY-Morrisville
- Troy University
- Tufts University
- University of UT
- University of Louisville
- University of Miami
- University of Nevada
- University of Utah
- Upper Iowa University
- Worcester Tech College

State/Local Government

- City & County of San Francisco - CA
- City of Colton - CA
- City of Milton - GA
- City of Oceanside - CA
- City of Raleigh - NC
- City of Tucson - AZ
- Douglas County Libraries - CO
- Freehold Township - NJ
- Los Angeles County Hall of Admin. Building - CA
- Martin County Fiscal Court - KY
- NYFD - NY
- Scottsdale Fire Station - AZ
- U.S. Mint - CO

Government Agencies

- AFIS/GSA - VA
- ETS/DOT - AK
- Federal Reserve - Washington, DC
- GSA/EPA Energy - GA
- Municipal Energy Office - PA
- The Pentagon - VA
- Smithsonian Institution - Washington, DC
- USGS - CA
- USGSA - NY
- U.S. Postal Service - CA
- U.S. Dept. of Agriculture - Washington, DC

Standard Meters

Class 1000 Single-Phase & Class 2000 Three-Phase kWh & kWh/Demand Meters



E-Mon D-Mon Class 1000 & 2000 kWh/Demand meters provide the basic building blocks of an affordable, effective and scalable energy management system. These easy-to-install meters can monitor anything from a single-phase circuit to a specific load panel to an entire building. Energy usage data can be viewed via the LCD display on the meter for easy, walk-up and read monitoring of energy consumption. Remote metering via E-Mon Energy Automatic Meter Reading (AMR) systems or Web-Mon Web Enabled Monitoring System is also easily interfaced for tenant billing, energy management and cost allocation based on actual usage, not estimation or ratio-based calculations.

Providing revenue-grade accuracy, Class 1000 & 2000 meters are independent lab-certified to ANSI C12.20 national accuracy standards of +/- 0.2% from 1% to 100% of rated load. All models provide a direct-read two-line alphanumeric LCD display (without multiplier) of cumulative kWh and real-time kW load.

E-Mon D-Mon standard meters are offered in standard JIC steel enclosures or optional NEMA 4X outdoor enclosures at no additional cost. MMU (Multiple Meter Unit) cabinets are also available containing up to 24 meters in a single, compact enclosure. Available models include:

Class 1000 - 1-phase/2-wire and 2-phase/3-wire configurations, with included low-voltage split-core current sensors.

Class 2000 - 2-phase/3-wire and 3-phase/3- or 4-wire configurations, with included current sensors from 100-3200A. A demand option displays the kW peak demand over a 15- or 30-minute demand interval.

Note: All meter kits include split-core current sensors.



Green Class Meters

Green Class & Green Class Net Meters



In addition to complying with several Energy Policy Act of 2005 (EPACT) guidelines, E-Mon's Green Class meters can materially help your facility gain points toward LEED Building Design + Construction (BD+C), Interior Design + Construction (ID+C) and Building Operations + Maintenance (O+M) certification. Available in a variety of voltage/current/wiring configurations, Green Class meters are also compatible with E-Mon Energy meter reading and billing software, Web-Mon web enabled monitoring systems and commercially available building automation systems.

With their scrolling display of six energy-usage parameters, Green Class meters provide a cost-effective way to benchmark and monitor energy usage trends and to estimated CO2 emissions. Green Meters are also ideal for measuring and verifying the on-going effectiveness of Renewable Energy, Demand Response and other major energy-related initiatives that can positively impact your bottom line.

Green Class & Green Class Net Meters are some of the most advanced green metering devices on the market today.

Green Class meters display cumulative kWh and real-time kW load. In addition, these meters allow the user to enter their local cost per kWh to provide accurate to-date energy costs and projected hourly costs based on the metered load. This meter is supplied standard in a green JIC steel enclosure and is optionally available in a gray NEMA 4X outdoor enclosure or MMU configuration for installation in MMU (Multiple Meter Unit) enclosures.

Green Class Net Meters are smart meters that are ideal for solar, wind and renewable energy applications where net metering energy data is required. The Green Class Net smart meter displays kWh delivered, received and Net kWh, kWh/Demand with peak date and time, Power Factor per Phase, Real-time load in kW, Amps per Phase and Volts per Phase. These meters also provide dual-protocol communication capabilities so that users can not only "walk up and read" the meter display, but they can monitor their energy usage via up to two building/energy management systems. The Green Class Net meter communicates via industry standard methods including RS-485, Ethernet and Pulse via a variety of protocols such as EZ7 (E-Mon Energy), Modbus RTU, Modbus TCP/IP, BACnet MS/TP, BACnet IP and LonWorks TP/FT-10. The Green Class Net meter also provides on-board set up capabilities for IP address, Meter date/time and ID codes for EZ7, Modbus and BACnet.

Note: All meters include one set of three (3) split-core current sensors.



Metering Product Overview

Smart Meters

Class 3200, 3400, 5000 and Din-Mon Smart Meters



E-Mon's smart meters for energy, power quality and BAS integration combine an extended feature set with a wider range of metering functions from basic to dual protocol, load control, net metering, expanded memory and storage, and more. The wide range of functionality offered by these meters allows you to choose the model and feature set that best fits your needs, without paying for unneeded bells and whistles.

Most smart meters provide more information and offer communication capabilities for integration with AMR (Automatic Meter Reading) systems, BAS systems, billing packages or M&V reporting programs via industry standard communication protocols. Class 3400, 5000 and Din-Mon D5 meters offer dual protocol communication for integration with two systems at the same time. This enhances the value of your meter investment by allowing you to obtain granular meter data from a single device acting as a billing meter and also as an independent building automation system meter.

E-Mon smart meters are UL Listed, independent lab-certified to ANSI C12.20 national accuracy standards (+/- 0.2% from 1% to 100% of rated load) and provide revenue grade accuracy. In addition, meters are available in a MV-90 compatible configuration. Available models include:

Class 3200 - Provides advanced display of energy data including kWh, kWh/Demand with peak date & time, power factor per phase, real-time load in kW and amps & volts per phase. Meter allows for on-board set up of meter date/time and ID code set up for communication options. Class 3200 meters are available as stand alone units in NEMA 4X outdoor enclosures with optional JIC steel or MMU configuration for installation into Multiple Meter Unit cabinets. User can choose one communication protocol for this unit; E-Z7 E-Mon Energy (standard), Modbus RTU or BACnet MS/TP.

Class 5000 - In addition to advanced display features and on-board set up options, the Class 5000 meter offers users the option of dual-protocol communication capabilities via RS-485 and Ethernet (optional telephone modem available). Users can choose from a variety of industry-standard communication protocols including; E-Z7 E-Mon Energy, Modbus RTU, Modbus TCP/IP, BACnet MS/TP, BACnet IP or LonWorks TP/FT-10. Meters are available in either NEMA 4X outdoor enclosures or indoor JIC steel enclosures. Class 5000 meters also provide two pulse outputs and two external meter inputs for water, gas, BTU, steam, etc. meters readable via E-Mon Energy software and phase loss alarming.

Class 3400 - The Class 3400 is the most advanced dual-protocol smart meter available on the market today. Features include advanced energy displays, on-board set up capabilities and dual protocol capabilities, but can also provide an optional expanded feature package which gives the user load control capabilities for load control/shedding, two external meter inputs for water, gas, BTU, etc. meters & two pulse outputs for kWh and kVARh. Class 3400 meters are supplied in NEMA 4X enclosures with JIC steel enclosures optionally available.



Din-Mon - Housed in standard DIN rail-mount enclosures, the single-protocol (Din-Mon D2) and dual-protocol (Din-Mon D5) meters facilitate integration of advanced energy monitoring into building automation systems, switchgear, control panels, server racks, renewable energy systems and other space-constrained applications.

Note: All meters include current sensors.

Multiple/Branch Circuit Energy Monitoring

Multi-Mon



E-Mon's Multi-Mon is a multiple branch circuit energy monitor that collects granular energy intelligence data for tenant billing, cost allocation and energy management. The device can accommodate up to 36 submetering points, giving total flexibility for configuration of up to 36 single-phase, 18 two-phase, 12 three-phase or any combination thereof. The Multi-Mon is ideal for submetering applications in apartment buildings, multi-tenant commercial facilities, institutions, data centers and more.

Multi-Mon is supplied with Power Software for meter set up and power quality analysis and is compatible with E-Mon Energy software via E-Z7 protocol for automatic meter reading, energy billing and profiling. In addition, Modbus RTU via RS-485 communication is standard and Modbus TCP/IP via Ethernet is optionally available.

Multi-Mon is compatible with both split & solid core current sensors for increased flexibility in installation. (Current sensors ordered separately, see Multi-Mon current sensor specifications for details. Multi-Mon is also optionally available pre-installed inside a JIC steel enclosure with lockable window panel and 3-phase voltage terminal block.

Power Quality Meters

PowerSmart⁺ Essential, PowerSmart⁺ Advanced & PowerSmart⁺ Socket Meters

E-Mon D-Mon PowerSmart⁺ family of power quality energy monitors and revenue-grade power quality socket meters are ideal for commercial, industrial and institutional energy monitoring applications. This family of products offers users unprecedented granularity of energy measurement data combined with advanced power quality analysis via the included Power Software.

PowerSmart⁺ meters combine real-time energy monitoring, advanced power quality functions and BAS communication in one integrated platform that meets the building sector's growing need for metering and monitoring solutions that help operators achieve a better level of performance, efficiency and cost savings with more granular management of the facility's total energy envelope.

Features of the PowerSmart⁺ family of power quality meters include, but are not limited to:

- Power Factor, THD, TDD, K-Factor, Sags, Swells, Spikes and Alarming
- Modbus RTU via RS-485 communication (standard) or Modbus TCP/IP via Ethernet (optional)
- Combines both static metering and time-of-use functionality
- Integral state-of-the-art EN50160-compliant power quality recorder
- Supplied with Power Software for meter set up and power quality analysis
- Selection of solid- and split-core current sensor options available

Available models include:



PowerSmart⁺ Essential Meter - Class 0.5S (+/- 0.5% accuracy) four-quadrant active and reactive energy polyphase static meter providing high-precision three-phase monitoring of V, I, PF, demand, V/I un-balance, frequency, load profile and more; offers panel-mount configuration for 4" round or 96x96 DIN opening; Graphical display provides real-time sine wave presentation, phasor diagrams and harmonics graphing.

PowerSmart⁺ Advanced Power Quality Energy Meter - Class 0.2 (+/- 0.2% accuracy) four-quadrant, multi-function three-phase energy meter with advanced power quality features including embedded harmonic analyzer, voltage and current THD, current TDD and K-Factor, inter harmonics THD up to 50th order harmonic; optionally available preinstalled in a JIC steel enclosure with lockable window panel and 3-phase voltage terminal block.



PowerSmart⁺ Revenue-Grade Power Quality Socket Meter - Precision Class 0.2 (+/-2% accuracy) three-phase active energy and power demand meter provides multiple tariffs and time-of-use capability, transformer and line losses, harmonic analyzer (to the 63th harmonic), volts and amps, power harmonics and power factor, phasor and symmetrical components), unique anti-tampering and self-test functions, standard form 9S socket configuration allows easy new or retrofit installation.

Other Metering Products

Electric Socket, Gas, Water, Steam, Fuel, Compressed Air, BTU ,etc.

In addition to E-Mon's standard meter offerings, there are a wide variety of specialized metering products available to meet your energy monitoring requirements. E-Mon offers a one-stop utility energy metering and monitoring solution from stand-alone metering to full E-Mon Energy software integration.

Third-party metering products include both hot and cold water meters in standard pipe sizes from 3/4" up to 6 and 8 inches, respectively, with larger, non-standard sizes available upon request. All come with pulse outputs for interfacing with external interval data recorders. Typically used in potable water applications, meters for wastewater and other non-potable specialty water applications are also available.

E-Mon also offers a range of gas, BTU, fuel, compressed air and steam meters, all providing standard pulse outputs for interfacing with external interval data recorders. The gas meters come in a range of types and sizes and are generally used for gas, propane and other gases may also be used. Meters are available in a variety of sizes and configurations to meet your specific application.

If your application requires a specialized meter that is not part of our standard catalog offering please contact us at (800) 334-3666 so that we can assist you in defining your requirements and specifying the appropriate product for your application.



Class 1000 Single-Phase kWh Meter

Standard Meters



Class 1000 Models

120V, 1-Phase, 2W (Supplied with (1) split-core current sensor)

E10-212025-JKIT (25 Amp)
E10-212050-JKIT (50 Amp)
E10-2120100JKIT (100 Amp)
E10-2120200JKIT (200 Amp)

120/208-240V, 1- or 2-Phase, 3W (Supplied with (2) split-core current sensors)

E10-320825-JKIT (25 Amp)
E10-320850-JKIT (50 Amp)
E10-3208100JKIT (100 Amp)
E10-3208200JKIT (200 Amp)

277V, 1-Phase, 2W (Supplied with (1) split-core current sensor)

E10-227725-JKIT (25 Amp)
E10-227750-JKIT (50 Amp)
E10-2277100JKIT (100 Amp)
E10-2277200JKIT (200 Amp)

Optional Meter Enclosures

Replace "J" in model number with optional enclosure specification.

Specification M - MMU Configuration
(ex. E10-3208100MKIT)

Specification R - NEMA 4X Raintight Enclosure
(ex. E10-212025-RKIT)

*For higher amperages contact factory at (800) 334-3666.

Features

- Direct-read 2-line alpha-numeric LCD display without multiplier displays cumulative kWh and "real-time" kW load.
- Available in MMU (Multiple Meter Unit) enclosures containing up to 24 meters in one compact enclosure.
- Revenue-grade accuracy.
- Patented 0-2 volt output split-core current sensors promote enhanced safety and accurate remote mounting of current sensors up to 2,000 feet from meter without power interruption. Optional solid-core sensors available in 100 & 200 amp.)
- Parallel up to three (3) sets of current sensors for cumulative reading.
- Current sensor installation diagnostics.
- Fixed pulse output.
- Non-volatile memory.
- Maintains reading in the event of power failure.
- Meter can be used on the following configurations:
 - 1-Phase, 2-Wire
 - 2-Phase, 3-WireFor other configurations, contact factory.
- Industrial grade JIC steel enclosure (standard) with padlocking hasp & mounting flanges for indoor installation. Knockouts: 1 1/16" (3/4" cond.) bottom, 7/8" (1/2" cond.) top.
- Optional NEMA 4X polycarbonate enclosure with padlocking hasp & mounting flanges for indoor/outdoor installation (stand alone) with one 1 1/16" KO on bottom of enclosure.
- UL/CUL Listed.
- Certified by independent test lab to ANSI C21.20 national accuracy standards. (+/- 0.2% from 1% to 100% of rated load.)
- California CTEP approved for use with solid-core current sensors. Listed by the California Energy Commission.
- New York City approved, Con Edison approved for RSP program.

Class 2000 Three-Phase kWh & kWh/kW Demand Meter

Standard Meters

Features

- Direct-read 2-line alpha-numeric LCD display without multiplier displays cumulative kWh and “real-time” kW load.
- Demand option displays kW/Demand and kW Peak date and time (15-minute interval standard, 30- or 60-minute interval available.)
- Available in MMU (Multiple Meter Unit) enclosures containing up to 24 meters in one compact enclosure.
- Patented 0-2 volt output split-core current sensors promote enhanced safety and accurate remote mounting of current sensors up to 2,000 feet from meter without power interruption. (Optional solid-core sensors available in 100 & 200 amp.) (three-phase meters include 3 split-core current sensors.)
- Onboard installation diagnostics & verification system.
- Parallel up to three (3) sets of current sensors for cumulative reading.
- Meter can be used on the following configurations:
 - 3-Phase, 4-Wire
 - 3-phase, 3-Wire
 For other configurations contact factory.
- Fixed-value pulse output.
- Industrial grade JIC steel enclosure (standard) with padlocking hasp & mounting flanges for indoor installation. Knockouts 1 1/16” (3/4” cond.) bottom, 7/8” (1/2” cond.) top.
- Optional NEMA 4X polycarbonate enclosure with padlocking hasp & mounting flanges for indoor/outdoor installation (stand alone) with one 1 1/16” KO on bottom of enclosure.
- Non-volatile memory.
- UL/CUL Listed.
- Revenue Grade Accuracy. Certified by independent test lab to ANSI C12.20 national accuracy standards. (+/- 0.2% from 1% to 100% of rated load.)
- California CTEP approved for use with solid-core current sensors. Listed by the California Energy Commission.
- New York City approved, Con Edison approved for RSP program.



Class 2000 Models

120/208-240V, 3-Phase

Amperage	KWH Meter	KWH/Demand Meter
100 Amp	E20-208100-JKIT	E20-208100-J-D-KIT
200 Amp	E20-208200-JKIT	E20-208200-J-D-KIT
400 Amp	E20-208400-JKIT	E20-208400-J-D-KIT
800 Amp	E20-208800-JKIT	E20-208800-J-D-KIT
1600 Amp	E20-2081600JKIT	E20-2081600J-D-KIT
3200 Amp	E20-2083200JKIT	E20-2083200J-D-KIT

277/480V, 3-Phase

Amperage	KWH Meter	KWH/Demand Meter
100 Amp	E20-480100-JKIT	E20-480100-J-D-KIT
200 Amp	E20-480200-JKIT	E20-480200-J-D-KIT
400 Amp	E20-480400-JKIT	E20-480400-J-D-KIT
800 Amp	E20-480800-JKIT	E20-480800-J-D-KIT
1600 Amp	E20-4801600JKIT	E20-4801600J-D-KIT
3200 Amp	E20-4803200JKIT	E20-4803200J-D-KIT

347/600V, 3-Phase (Wye Configuration)

Amperage	KWH Meter	KWH/Demand Meter
100 Amp	E20-600100-JKIT	E20-600100-J-D-KIT
200 Amp	E20-600200-JKIT	E20-600200-J-D-KIT
400 Amp	E20-600400-JKIT	E20-600400-J-D-KIT
800 Amp	E20-600800-JKIT	E20-600800-J-D-KIT
1600 Amp	E20-6001600JKIT	E20-6001600J-D-KIT
3200 Amp	E20-6003200JKIT	E20-6003200J-D-KIT

High Voltage Application Meters (For Use with CTs & PTs)

E20-12025HV-JKIT

Optional Meter Enclosures

Replace “J” in model number with optional enclosure specification.

Specification M - MMU Configuration
(ex. E20-208100-MKIT)

Specification R - NEMA 4X Raintight Enclosure
(ex. E20-6001600RKIT)



Green Class Models

120/208-240V, 3-Phase

E20-208100-J-G-KIT (100 Amp)
 E20-208200-J-G-KIT (200 Amp)
 E20-208400-J-G-KIT (400 Amp)
 E20-208800-J-G-KIT (800 Amp)
 E20-2081600J-G-KIT (1600 Amp)
 E20-2083200J-G-KIT (3200 Amp)

277/480V, 3-Phase

E20-480100-J-G-KIT (100 Amp)
 E20-480200-J-G-KIT (200 Amp)
 E20-480400-J-G-KIT (400 Amp)
 E20-480800-J-G-KIT (800 Amp)
 E20-4801600J-G-KIT (1600 Amp)
 E20-4803200J-G-KIT (3200 Amp)

347/600V, 3-Phase (Wye Configuration)

E20-600100-J-G-KIT (100 Amp)
 E20-600200-J-G-KIT (200 Amp)
 E20-600400-J-G-KIT (400 Amp)
 E20-600800-J-G-KIT (800 Amp)
 E20-6001600J-G-KIT (1600 Amp)
 E20-6003200J-G-KIT (3200 Amp)

Optional Meter Enclosures

Replace "J" in model number with optional enclosure specification.

Specification M - MMU Configuration
 (ex. E20-208100-M-G-KIT)

Specification R - NEMA 4X Raintight Enclosure
 (ex. E20-208400-R-G-KIT)

* 3-phase meter kits include one set of three (3) split-core current sensors.

Features

- Direct-read 2-line alpha-numeric LCD display without multiplier displays cumulative kWh, peak demand w/date & time and "real-time" kW load.
- User entered cost per kWh provides to-date energy cost and projected hourly cost based on metered load.
- Displays total carbon (CO₂) emissions in pounds (lbs.) and indicates hourly emissions based on metered load.
- Available in MMU (Multiple Meter Unit) enclosures containing up to 24 meters in one compact enclosure.
- 0-2 volt output split-core current sensors promote enhanced safety and allow remote mounting of current sensors up to 2,000 feet from meter without power interruption. (Optional solid-core sensors available in 100 & 200 amp.) (3-phase meters include 3 split-core current sensors.)
- Onboard installation diagnostics & verification system.
- Parallel up to three (3) sets of current sensors for cumulative reading.
- Meter can be used on the following configurations:
 - 3-Phase, 4-Wire
 - 3-Phase, 3-Wire
 For other configurations contact factory.
- Fixed-value pulse output.
- Green industrial grade JIC steel enclosure (standard) with padlocking hasp and mounting flanges for indoor installation with 1 1/16" KO (3/4" cond.) bottom, 7/8" (1/2" cond.) top.
- Optional gray NEMA 4X polycarbonate enclosure with padlocking hasp & mounting flanges for indoor/outdoor installation (stand alone) with one 1 1/16" KO on bottom of enclosure.
- Non-volatile memory.
- UL/CUL Listed.
- Revenue Grade Accuracy. Certified by independent test lab to ANSI C12.20 national accuracy standards. (+/- 0.2% from 1% to 100% of rated load.)
- New York City approved, Con Edison approved for RSP program.

Dual-Protocol Green Class Meters

Features

- Advanced 4-line display showing:
 - kWh delivered, received and Net kWh
 - kW demand (with peak date & time)
 - Power factor per phase
 - Volts per phase
 - Amps per Phase
 - Real-time load in kW
- On-board set-up option for:
 - IP address
 - ID codes for EZ7, Modbus and BACnet
 - Meter date/time
- 0-2 volt output split-core current sensors allow for enhanced safety & accurate remote mounting of sensors up to 500 feet from meter without power interruption. (Optional solid-core sensors available.)
- Onboard installation diagnostics and verification system.
- Two external meter inputs (water, gas, etc.) (Channels 5 & 6)
- Phase loss alarm. (N.O. Contact)
- Built-in RS-485 communication capability supports up to 52 Class 3200, 3400, 5000, Din-Mon D2 or Din-Mon D5 meters and/or IDR interval recorders (not to exceed 52 devices/channel). Cabling can either be daisy-chain or star configuration, 3-cond., 18-22 AWG, up to 4,000 cable feet total per channel.
- Communications include built-in RS-485 & Ethernet, and optional Telephone Modem.
- Protocols
 - EZ7
 - Modbus RTU
 - Modbus TCP/IP
 - BACnet MS/TP*
 - BACnet IP*
 - LonWorks TP/FT-10
- Records kWh and kVARh delivered, kWh and kVARh received in first four channels. Data stored in 15-min intervals for up to 72 days or 5-minute intervals for up to 24 days. Maintains data in a first-in, first-out format.
- Compatible with E-Mon Energy software via EZ7 protocol for automatic meter reading, energy billing and profiling.
- Meter is designed for use on both 3-phase, 3-wire (delta) and 3-phase, 4-wire (wye) circuits (includes 3 split-core current sensors). Optional single-phase, 3-wire configuration available. (includes 2 split-core current sensors.)
- Green JIC steel enclosure with padlocking hasp & mounting flanges for indoor installation with one 1 1/16" KO (3/4" cond.) on bottom of enclosure.
- Optional gray NEMA 4X polycarbonate enclosure available with padlocking hasp & mounting flanges for indoor/outdoor installation (stand alone) with one 1 1/16" KO on bottom of enclosure.
- Approvals:
 - UL/CUL Listed.
 - Certified by independent test lab to ANSI C12.20 national accuracy standards. (+/- 0.2% from 1% to 100% of rated load.)
 - CE Mark approved.
 - Meter meets or exceeds MID accuracy standards.
 - BACnet protocol is BTL certified. LonWorks protocol is LonMark Certified.
- MV-90 compatible (with EZ7 only.)



Green Class Net Meter Models

120/208-240V, 127/220V, 3-Phase

E50-208100-J*-N-KIT (100 Amp)
 E50-208200-J*-N-KIT (200 Amp)
 E50-208400-J*-N-KIT (400 Amp)
 E50-208800-J*-N-KIT (800 Amp)
 E50-2081600J*-N-KIT (1600 Amp)
 E50-2083200J*-N-KIT (3200 Amp)

220/380V, 230/400V, 240/415V, 3-Phase

E50-400100-J*-N-KIT (100 Amp)
 E50-400200-J*-N-KIT (200 Amp)
 E50-400400-J*-N-KIT (400 Amp)
 E50-400800-J*-N-KIT (800 Amp)
 E50-4001600J*-N-KIT (1600 Amp)
 E50-4003200J*-N-KIT (3200 Amp)

277/480V, 3-Phase

E50-480100-J*-N-KIT (100 Amp)
 E50-480200-J*-N-KIT (200 Amp)
 E50-480400-J*-N-KIT (400 Amp)
 E50-480800-J*-N-KIT (800 Amp)
 E50-4801600J*-N-KIT (1600 Amp)
 E50-4803200J*-N-KIT (3200 Amp)

347/600V, 3-Phase (Wye Configuration)

E50-600100-J*-N-KIT (100 Amp)
 E50-600200-J*-N-KIT (200 Amp)
 E50-600400-J*-N-KIT (400 Amp)
 E50-600800-J*-N-KIT (800 Amp)
 E50-6001600J*-N-KIT (1600 Amp)
 E50-6003200J*-N-KIT (3200 Amp)

Optional Meter Enclosures

Meters supplied standard in Green JIC steel enclosures.
 Not available in MMU Configuration
 To order a Gray NEMA 4X outdoor enclosure replace "J" in model number with "R" (E50-208100-R01-N-KIT)

Communication Protocol & Option Packages

Specify protocol package when ordering all meters.
 Replace * in model number with protocol package specification below.

RS-485 Port		Specify
EZ7	EZ7 Ethernet	01
Modbus RTU	EZ7 Ethernet	02
BACnet MS/TP	EZ7 Ethernet	03
EZ7	Modbus TCP/IP	04
EZ7	BACnet IP	05
Modbus RTU	Modbus TCP/IP	06
LonWorks TP/FT-10	EZ7 Ethernet	07
LonWorks TP/FT-10	Modbus TCP/IP	08
EZ7 w/Telephone Modem	EZ7 Ethernet	09
EZ7 w/Telephone Modem	Modbus TCP/IP	10
EZ7 w/Telephone Modem	BACnet IP	11

Single Phase Option (2 current sensors)

To order a single-phase, 3-wire meter kit replace "N" with "NSP" in the model number. Ex. E50-208100-J02NSPKIT



Class 3200 Models

120/208-240V, 3-Phase

E32-208100-REZ7KIT (100 Amp)
 E32-208200-REZ7KIT (200 Amp)
 E32-208400-REZ7KIT (400 Amp)
 E32-208800-REZ7KIT (800 Amp)
 E32-2081600REZ7KIT (1600 Amp)
 E32-2083200REZ7KIT (3200 Amp)

220/380V, 230/400V, 240/415V, 3-Phase

E32-400100-REZ7KIT (100 Amp)
 E32-400200-REZ7KIT (200 Amp)
 E32-400400-REZ7KIT (400 Amp)
 E32-400800-REZ7KIT (800 Amp)
 E32-4001600REZ7KIT (1600 Amp)
 E32-4003200REZ7KIT (3200 Amp)

277/480V, 3-Phase

E32-480100-REZ7KIT (100 Amp)
 E32-480200-REZ7KIT (200 Amp)
 E32-480400-REZ7KIT (400 Amp)
 E32-480800-REZ7KIT (800 Amp)
 E32-4801600REZ7KIT (1600 Amp)
 E32-4803200REZ7KIT (3200 Amp)

347/600V, 3-Phase (Wye Configuration)

E32-600100-REZ7KIT (100 Amp)
 E32-600200-REZ7KIT (200 Amp)
 E32-600400-REZ7KIT (400 Amp)
 E32-600800-REZ7KIT (800 Amp)
 E32-6001600REZ7KIT (1600 Amp)
 E32-6003200REZ7KIT (3200 Amp)

High Voltage Application Meters (For Use with CTs & PTs)

E32-12025HVREZ7KIT

Single Phase Option (2 current sensors)

To order a single-phase, 3-wire meter add "-SP" before KIT in the model number. Ex. E32-208100-REZ7-SPKIT

Optional Meter Enclosures

Meters supplied standard in NEMA 4X outdoor enclosures. To order a different enclosure replace "R" in model number with optional enclosure specification.

MMU Configuration - Specification M
 (ex. E32-208100-MEZ7KIT)

JIC Steel Enclosure - Specification J
 (ex. E32-208400-JEZ7KIT)

Communication Protocol Options

Meters supplied standard with EZ7 protocol. To order a different communication protocol replace "EZ7" in model number with optional protocol specification.

Modbus RTU - Specify RTU (E32-480100-JRTUKIT)
 BACnet MS/TP - Specify BAC (E32-600100-RBACKIT)

Features

- Advanced 4-line display showing kWh, kW demand (with peak date & time), power factor per phase, real-time load in kW, amps per phase and volts per phase. Meter includes on-board set-up option for meter date/time and ID codes for communication options.
- Available in MMU (Multiple Meter Unit) enclosures containing up to 24 meters in one compact enclosure.
- 0-2 volt output split-core current sensors allow for enhanced safety and accurate remote mounting of sensors up to 500 feet from meter without power interruption. (Optional solid-core sensors available.)
- Onboard installation diagnostics and verification system.
- Built-in RS-485 communication capability supports up to 52 Class 3200, 3400, 5000, Din-Mon D2 or Din-Mon D5 meters and/or IDR interval recorders (not to exceed 52 devices/channel). Cabling can either be daisy-chain or star configuration, 3-cond., 18-22 AWG, up to 4,000 cable feet total per channel.
- RS-485 protocol options include E-Mon Energy EZ7 (standard), Modbus RTU or BACnet MS/TP.
- Records kWh and kVARh delivered, kWh & kVARh received in first 4 channels. Data stored in 15-min. intervals for up to 72 days or 5-min. intervals for up to 24 days. Maintains interval data storage in a first-in, first-out format.
- Compatible with E-Mon Energy software via EZ7 protocol for automatic meter reading, billing and profiling of interval energy data. Ethernet communication available when used with Ether-Mon Key.
- Meter is designed for use on both 3-phase, 3-wire (delta) and 3-phase, 4-wire (wye) circuits. (includes 3 split-core current sensors.) Optional single-phase, 3-wire configuration available. (includes 2 split-core current sensors.)
- Outdoor NEMA 4X polycarbonate enclosure (standard) with padlocking hasp & mounting flanges for indoor/outdoor installation (stand alone) with one 1 1/16" KO on bottom of enclosure.
- Optional Enclosure: Industrial grade JIC steel enclosure with padlocking hasp & mounting flanges for indoor installation. (stand alone) Knockouts: 1 1/16" (3/4" cond) on bottom and 7/8" (1/2" cond) on top of enclosure.
- UL/CUL Listed. Certified by independent test lab to ANSI C12.20 national accuracy standards. (+/- 0.2% from 1% to 100% of rated load.)
- CE Mark approved.
- Meter meets or exceeds MID accuracy standards.
- MV-90 Compatible (EZ7 only)

Dual-Protocol Smart Meters

Features

- Advanced 4-line large display showing kWh, kW demand (with peak date & time), power factor per phase, real-time load in kW, amps per phase and volts per phase. Meter includes on-board set-up option for IP address, meter date/time, ID codes for communication options and load control settings.
- Optional expanded feature package provides additional features including load control option for load control/shedding, two external meter inputs (water, gas, BTU, etc.) (stored in channels 5 & 6) and two pulse outputs (one kWh and one kVARh).
- 0-2 volt output split-core current sensors allow for enhanced safety & accurate remote mounting of sensors up to 500 feet from meter without power interruption. (Optional solid-core sensors available.)
- Onboard installation diagnostics and verification system.
- Built-in RS-485 communication capability supports up to 52 Class 3200, 3400, 5000, Din-Mon D2 or Din-Mon D5 meters and/or IDR interval recorders (not to exceed 52 devices/channel). Cabling can either be daisy-chain or star configuration, 3-cond., 18-22 AWG, up to 4,000 cable feet total per channel.
- Built-in communications include RS-485 & Ethernet, pulse output and optional telephone Modem.
- Protocols
 - EZ7
 - Modbus RTU
 - Modbus TCP/IP
 - BACnet MS/TP*
 - BACnet IP*
 - LonWorks TP/FT-10
- Records kWh and kVARh delivered, kWh and kVARh received in first four channels. Data stored in 15-min intervals for up to 72 days or 5-minute intervals for up to 24 days. Maintains data in a first-in, first-out format.
- Compatible with E-Mon Energy software via EZ7 protocol for automatic meter reading, energy billing and profiling.
- Meter is designed for use on both 3-phase, 3-wire (delta) & 3-phase, 4-wire (wye) circuits. (includes 3 split-core current sensors) Optional single-phase, 3-wire configuration available. (includes 2 split-core current sensors.)
- Outdoor NEMA 4X polycarbonate enclosure (standard) with padlocking hasp & mounting flanges for indoor/outdoor installation (stand alone) with one 1 1/16" KO on bottom of enclosure.
- Optional industrial grade JIC steel enclosure with padlocking hasp & mounting flanges for indoor installation (stand alone) with one 1 1/16" KO on bottom of enclosure.
- Approvals:
 - UL/CUL Listed.
 - Certified by independent test lab to ANSI C12.20 accuracy standards. (+/- 0.2% from 1% to 100% of rated load.)
 - Meter meets or exceeds MID accuracy standards.
 - BACnet protocol is BTL verified. LonWorks protocol is LonMark certified.
- MV-90 compatible (with EZ7 only.)



Class 3400 Models

120/208-240V, 127/220V, 3-Phase

E34-208100-R*KIT (100 Amp)
 E34-208200-R*KIT (200 Amp)
 E34-208400-R*KIT (400 Amp)
 E34-208800-R*KIT (800 Amp)
 E34-2081600R*KIT (1600 Amp)
 E34-2083200R*KIT (3200 Amp)

220/380V, 230/400V, 240/415V, 3-Phase

E34-400100-R*KIT (100 Amp)
 E34-400200-R*KIT (200 Amp)
 E34-400400-R*KIT (400 Amp)
 E34-400800-R*KIT (800 Amp)
 E34-4001600R*KIT (1600 Amp)
 E34-4003200R*KIT (3200 Amp)

277/480V, 3-Phase

E34-480100-R*KIT (100 Amp)
 E34-480200-R*KIT (200 Amp)
 E34-480400-R*KIT (400 Amp)
 E34-480800-R*KIT (800 Amp)
 E34-4801600R*KIT (1600 Amp)
 E34-4803200R*KIT (3200 Amp)

347/600V, 3-Phase (Wye Configuration)

E34-600100-R*KIT (100 Amp)
 E34-600200-R*KIT (200 Amp)
 E34-600400-R*KIT (400 Amp)
 E34-600800-R*KIT (800 Amp)
 E34-6001600R*KIT (1600 Amp)
 E34-6003200R*KIT (3200 Amp)

High Voltage Application Meters (For Use with CTs & PTs)

E34-12025HVR01KIT

Optional Meter Enclosures

Meters supplied standard in NEMA 4X outdoor enclosures. Not available in MMU Configuration. To order a JIC steel enclosure replace "R" in model number with "J" (E34-208100-J01KIT)

Communication Protocol & Option Packages

Specify protocol package when ordering all meters. Replace * in model number with protocol package specification below.

RS-485 Port		Specify
EZ7	EZ7 Ethernet	01
Modbus RTU	EZ7 Ethernet	02
BACnet MS/TP	EZ7 Ethernet	03
EZ7	Modbus TCP/IP	04
EZ7	BACnet IP	05
Modbus RTU	Modbus TCP/IP	06
LonWorks TP/FT-10	EZ7 Ethernet	07
LonWorks TP/FT-10	Modbus TCP/IP	08
EZ7 w/Telephone Modem	EZ7 Ethernet	09
EZ7 w/Telephone Modem	Modbus TCP/IP	10
EZ7 w/Telephone Modem	BACnet IP	11

Expanded Feature Package

To order meters with the expanded feature package add "-X-" before the word KIT in the model. (E34-208100-R05-X-KIT)

Single Phase Option (2 current sensors)

Single Phase Standard Meter: Add "-SP" before KIT in model.
 Example: E34-208100-R01-SPKIT

Single Phase Expanded Feature Meter: Add "XSP" before KIT in model.
 Example: E34-208100-R01XSPKIT



Class 5000 Models

120/208-240V, 127/220V, 3-Phase

E50-208100-R*KIT (100 Amp)
E50-208200-R*KIT (200 Amp)
E50-208400-R*KIT (400 Amp)
E50-208800-R*KIT (800 Amp)
E50-2081600JR*KIT (1600 Amp)
E50-2083200R*KIT (3200 Amp)

220/380V, 230/400V, 240/415V, 3-Phase

E50-400100-R*KIT (100 Amp)
E50-400200-R*KIT (200 Amp)
E50-400400-R*KIT (400 Amp)
E50-400800-R*KIT (800 Amp)
E50-4001600R*KIT (1600 Amp)
E50-4003200R*KIT (3200 Amp)

277/480V, 3-Phase

E50-480100-R*KIT (100 Amp)
E50-480200-R*KIT (200 Amp)
E50-480400-R*KIT (400 Amp)
E50-480800-R*KIT (800 Amp)
E50-4801600R*KIT (1600 Amp)
E50-4803200R*KIT (3200 Amp)

347/600V, 3-Phase (Wye Configuration)

E50-600100-R*KIT (100 Amp)
E50-600200-R*KIT (200 Amp)
E50-600400-R*KIT (400 Amp)
E50-600800-R*KIT (800 Amp)
E50-6001600R*KIT (1600 Amp)
E50-6003200R*KIT (3200 Amp)

High Voltage Application Meters (For Use with CTs & PTs)

E50-12025HVR01KIT

Optional Meter Enclosures

Meters supplied standard in NEMA 4X outdoor enclosures. Not available in MMU Configuration. To order a JIC steel enclosure replace "R" in model number with "J" (ex. E50-208400-J01KIT)

Communication Protocol & Option Packages

Specify protocol package when ordering all meters. Replace * in model number with protocol package specification below.

RS-485 Port		Specify
EZ7	EZ7 Ethernet	01
Modbus RTU	EZ7 Ethernet	02
BACnet MS/TP	EZ7 Ethernet	03
EZ7	Modbus TCP/IP	04
EZ7	BACnet IP	05
Modbus RTU	Modbus TCP/IP	06
LonWorks TP/FT-10	EZ7 Ethernet	07
LonWorks TP/FT-10	Modbus TCP/IP	08
EZ7 w/Telephone Modem	EZ7 Ethernet	09
EZ7 w/Telephone Modem	Modbus TCP/IP	10
EZ7 w/Telephone Modem	BACnet IP	11

Single Phase Option (2 current sensors)

To order a single-phase, 3-wire meter add "-SP" before KIT in the model number. Ex. E50-208100-REZ7-SPKIT

Features

- Advanced 4-line display showing kWh, kW demand (with peak date & time), power factor per phase, real-time load in kW, amps per phase and volts per phase. Meter includes on-board set-up option for meter date/time, IP address and ID codes for communication options.
- 0-2 volt output split-core current sensors allow for enhanced safety and accurate remote mounting of sensors up to 500 feet from meter without power interruption. (Optional solid-core sensors available.)
- Onboard installation diagnostics and verification system.
- Two pulse outputs & two external inputs (water, gas, BTU, etc.) (Channels 5 & 6, available from E-Mon Energy only).
- Phase loss alarm (N.O. Contact)
- Built-in RS-485 communication capability supports up to 52 Class 3200, 3400, 5000, Din-Mon D2 or Din-Mon D5 meters and/or IDR interval recorders (not to exceed 52 devices/channel). Cabling can either be daisy-chain or star configuration, 3-cond., 18-22 AWG, up to 4,000 cable feet total per channel.
- Built-in RS-485 & Ethernet Communications. Optional Telephone Modem available.
- Protocols
 - EZ7 (E-Mon Energy) - BACnet MS/TP*
 - Modbus RTU - BACnet IP*
 - Modbus TCP/IP - LonWorks TP/FT-10
- Records kWh and kVARh delivered, kWh & kVARh received in first 4 channels. Data stored in 15-min. intervals for up to 72 days or 5-min. intervals for up to 24 days. Maintains interval data storage in a first-in, first-out format.
- Compatible with E-Mon Energy software via EZ7 protocol for automatic meter reading, energy billing and profiling.
- Meter is designed for use on both 3-phase, 3-wire (delta) and 3-phase, 4-wire (wye) circuits. (includes 3 split-core current sensors.) Optional single-phase, 3-wire configuration available. (includes 2 split-core current sensors.)
- Outdoor NEMA 4X polycarbonate enclosure (standard) with padlocking hasp & mounting flanges for indoor/outdoor installation (stand alone) with one 1 1/16" KO on bottom of enclosure.
- Optional Industrial grade JIC steel enclosure with padlocking hasp & mounting flanges for indoor installation. (stand alone) Knockouts: 1 1/16" (3/4" cond) bottom & 7/8" (1/2" cond) top.
- Approvals:
 - UL/CUL Listed.
 - Certified by independent lab to ANSI C12.20 accuracy standards. (+/- 0.2% from 1% to 100% of rated load.)
 - CE Mark approved.
 - Meter meets or exceeds MID accuracy standards.
 - BACnet protocol is BTL certified. LonWorks protocol is LonMark certified.
- MV-90 Compatible. (EZ7 only)

Features

- Advanced 4-line display showing:
 - kWh
 - Power factor per phase
 - Amps per phase
 - kW demand (w/ peak date & time)
 - Real-time in KW
 - Volts per phase
- On-board set-up option for:
 - Meter date/time
 - ID codes for EZ7, Modbus & BACnet
- Meter provides bidirectional meter data via communication protocols for net metering applications:
 - kWh & kVARh delivered
 - kWh & kVARh received
- 0.333 volt output split-core current sensors (standard) allow for enhanced safety and accurate remote mounting of sensors up to 500 feet from meter. (Optional solid-core sensors and 100 mA output current sensors available.)
- Meters can be ordered without current sensors and used with commercially available 0.333V & 100mA output current sensors. (Specify V3 (0.333V) or C1 (100mA) in model number and order without current sensors when using third-party current sensors.)
- Two customer configurable pulse outputs:
 - Watt-hour and VAR-hour pulse outputs or
 - Watt-hour and phase loss (N.O. Contact)
- Onboard installation diagnostics and verification system.
- Built-in RS-485 communication capability supports up to 52 Class 3200, 3400, 5000, Din-Mon D2 or Din-Mon D5 meters and/or IDR interval recorders (not to exceed 52 devices/channel). Cabling can either be daisy-chain or star configuration, 3-cond., 18-22 AWG, up to 4,000 cable feet total per channel.
- RS-485 Protocol Options
 - E-Mon Energy EZ7
 - Modbus RTU
 - BACnet MS/TP* (BTL Testing Certified)
- Records kWh and kVARh delivered, kWh and kVARh received in first four channels. Data stored in 15-minute intervals for up to 72 days or 5-minute intervals for up to 24 days. Maintains data in a first-in, first-out format. (Interval data not available via BACnet.)
- Compatible with E-Mon Energy software via EZ7 protocol for automatic meter reading, energy billing and profiling.
- Meter is designed for use on both 3-phase, 3-wire (delta) and 3-phase, 4-wire (wye) circuits. Optional 1- and 2-element configurations available.
- Non-metallic enclosure with DIN rail mounting and surface mounting flexibility.
- UL/CUL Listed. Meter meets or exceeds ANSI C12.20 national accuracy standards. (+/- 0.2% from 1% to 100% of rated load.)
- Meter meets or exceeds MID accuracy standards.



Din-Mon D2 Models

120/208-240V, 12/220V, 3-Phase

E-D2-208100-SEZ7SPL3-V3KIT3 (100 Amp)
 E-D2-208200-SEZ7SPL3-V3KIT3 (200 Amp)
 E-D2-208400-SEZ7SPL3-V3KIT3 (400 Amp)
 E-D2-208800-SEZ7SPL3-V3KIT3 (800 Amp)

220/380V, 230/400V, 240/415V, 3-Phase

E-D2-400100-SEZ7SPL3-V3KIT3 (100 Amp)
 E-D2-400200-SEZ7SPL3-V3KIT3 (200 Amp)
 E-D2-400400-SEZ7SPL3-V3KIT3 (400 Amp)
 E-D2-400800-SEZ7SPL3-V3KIT3 (800 Amp)

277/480V, 3-Phase

E-D2-480100-SEZ7SPL3-V3KIT3 (100 Amp)
 E-D2-480200-SEZ7SPL3-V3KIT3 (200 Amp)
 E-D2-480400-SEZ7SPL3-V3KIT3 (400 Amp)
 E-D2-480800-SEZ7SPL3-V3KIT3 (800 Amp)

347/600V, 3-Phase

E-D2-600100-SEZ7SPL3-V3KIT3 (100 Amp)
 E-D2-600200-SEZ7SPL3-V3KIT3 (200 Amp)
 E-D2-600400-SEZ7SPL3-V3KIT3 (400 Amp)
 E-D2-600800-SEZ7SPL3-V3KIT3 (800 Amp)

RS-485 Communication Protocols

Above models supplied with EZ7 communication protocol for use with E-Mon Energy software.

Optional communication protocols:

- Modbus RTU - Replace EZ7 in model with "RTU"
 ex. E-D2-480100SRTUSPL1-V3KIT1

- BACnet MS/TP - Replace EZ7 in model with "BAC"
 ex. E-D2-208200SBACSPL3-V3KIT3

Ordering Options

Solid Core current sensors - Replace "SPL" in model with "SCS" (100A & 200A only) ex. E-D2-480400-SEZ7SCS3-V3KIT3

100mA current sensors instead of 0.333V sensors - Replace "V3" in model with "C1" (200A, 400A and 800A only)
 ex. E-D2-480200-SEZ7SPL3-C1KIT3

Single Element meter - Replace "SPL3" or "SCS3" with "SPL1" or "SCS1" AND change "KIT3" to "KIT1" ex. E-D2-208100-SEZ7SPL1-V3KIT1

2-Element meter - Replace "SPL3" or "SCS3" with "SPL2" or "SCS2" AND change "KIT3" to "KIT2" ex. E-D2-208100-SEZ7SPL2-KIT2

To order meters without current sensors remove KIT1, KIT2 or KIT3 from the model. NOTE: Be sure to specify if the meter is single element, 2-element or 3-phase and what type of sensors will be used (0.333V or 100mA) when ordering without sensors.



Din-Mon D5 Models

120/208-240V, 127/220V, 3-Phase

- E-D5-208100-S*SPL3-V3KIT3 (100 Amp)
- E-D5-208200-S*SPL3-V3KIT3 (200 Amp)
- E-D5-208400-S*SPL3-V3KIT3 (400 Amp)
- E-D5-208800-S*SPL3-V3KIT3 (800 Amp)

220/380V, 230/400V, 240/415V, 3-Phase

- E-D5-400100-S*SPL3-V3KIT3 (100 Amp)
- E-D5-400200-S*SPL3-V3KIT3 (200 Amp)
- E-D5-400400-S*SPL3-V3KIT3 (400 Amp)
- E-D5-400800-S*SPL3-V3KIT3 (800 Amp)

277/480V, 3-Phase

- E-D5-480100-S*SPL3-V3KIT3 (100 Amp)
- E-D5-480200-S*SPL3-V3KIT3 (200 Amp)
- E-D5-480400-S*SPL3-V3KIT3 (400 Amp)
- E-D5-480800-S*SPL3-V3KIT3 (800 Amp)

347/600V, 3-Phase

- E-D5-600100-S*SPL3-V3KIT3 (100 Amp)
- E-D5-600200-S*SPL3-V3KIT3 (200 Amp)
- E-D5-600400-S*SPL3-V3KIT3 (400 Amp)
- E-D5-600800-S*SPL3-V3KIT3 (800 Amp)

Communication Protocol & Option Packages

Specify protocol package when ordering all meters.
Replace * in model number with protocol package specification below.

RS-485 Port		Specify
EZ7	EZ7 Ethernet	01
Modbus RTU	EZ7 Ethernet	02
BACnet MS/TP	EZ7 Ethernet	03
EZ7	Modbus TCP/IP	04
EZ7	BACnet IP	05
Modbus RTU	Modbus TCP/IP	06
EZ7	LonWorks TP/FT-10	12

Ordering Options

- Solid Core current sensors - Replace "SPL" in model with "SCS" (100A & 200A only) Ex. E-D5-480400S04SCS3-V3KIT3
- 100 mA current sensors instead of 0.333V sensors - Replace "V3" in model number with "C1" (200A, 400A & 800A only) Ex. E-D5-480200-S02SPL3-C1KIT3
- Single element meter - Replace "SPL3" or "SCS3" with "SPL1" or "SCS1" AND change "KIT3" to "KIT1"
Ex. E-D5-208200-S01SPL1-C1KIT1
- 2-element meter - Replace "SPL3" or "SCS3" with "SPL2" or "SCS2" AND change "KIT3" to "KIT2"
Ex. E-D5-208200-S01SPL2-C1KIT2
- To order meters without current sensors remove KIT1, KIT2 or KIT3 from the model. NOTE: Be sure to specify if the meter is single element, 2-element or 3-phase and what type of sensors will be used (0.333V or 100mA) when ordering without current sensors.

Features

- Advanced 4-line display showing:
 - kWh
 - Power factor per phase
 - Amps per phase
 - kW demand (w/ peak date & time)
 - Real-time in KW
 - Volts per phase
- On-board set-up option for:
 - IP address
 - ID codes for EZ7, Modbus & BACnet
 - Meter date/time
- Dual-protocol functionality allows operation for RS-485/Ethernet or RS-485/LonWorks communication simultaneously with selectable BAS protocols. Supports independent communication to E-MON's Automatic Meter Reading (AMR) system and Building Automation System (BAS or other front-end monitoring systems).
- 0.333 volt output split-core current sensors (standard) allow for enhanced safety and accurate remote mounting of sensors up to 500 feet from meter. (Optional solid-core sensors and 100 mA output current sensors available.)
- Meters can be ordered without current sensors and used with commercially available 0.333V & 100mA output current sensors. (Specify V3 (0.333V) or C1 (100mA) in model number and order without current sensors when using third-party current sensors.)
- Two customer configurable pulse outputs:
 - Watt-hour and VAR-hour pulse outputs or
 - Watt-hour and phase loss (N.O. Contact)
- Onboard installation diagnostics and verification system.
- Built-in RS-485 communication capability supports the following connection configurations (or combinations not to exceed 52 devices per channel):
 - Up to 52 Din-Mon D2, Din-Mon D5, Class 3200, 3400 and 5000 meters and/or IDR interval recorders
 - Cabling using 3-conductor, 18-22 AWG, up to 4,000 cable feet total.
- Protocols (BACnet protocols are BTL Certified, LonWorks protocol is LonMark certified)
 - EZ7
 - Modbus RTU
 - Modbus TCP/IP
 - BACnet MS/TP*
 - BACnet IP*
 - LonWorks TP/FT-10
- Records kWh and kVARh delivered, kWh and kVARh received in first four channels. Data stored in 15-minute intervals for up to 72 days or 5-minute intervals for up to 24 days. Maintains data in a first-in, first-out format. (Interval data not available via BACnet or LonWorks.)
- Compatible with E-Mon Energy software via EZ7 protocol for automatic meter reading, energy billing and profiling.
- Meter is designed for use on both 3-phase, 3-wire (delta) and 3-phase, 4-wire (wye) circuits. Optional 1- and 2-element configurations available.
- Non-metallic enclosure with DIN rail mounting and surface mounting flexibility.
- UL/CUL Listed. Meter meets or exceeds ANSI C12.20 national accuracy standards. (+/- 0.2% from 1% to 100% of rated load.)
- Meter meets or exceeds MID accuracy standards.



Multi-Mon Models

Multi-Mon 36-channel branch circuit energy monitor (no current sensors)

E-MM-RTU-Y-N (Wye Configuration)
E-MM-RTU-D-N (Delta Configuration)

Options

Modbus TCP/IP communication via Ethernet-Add suffix "-ETH" to the end of the model.
Example: E-MM-RTU-Y-N-ETH

Wired cabinet option - Add suffix "-MWC" to the end of the model.
Example: E-MM-RTU-Y-N-MWC

Note: Current sensors ordered separately. See Multi-Mon current sensor spec for details.

Note: RS-485 Key required for communicating with Power Software.

Features

- Multi-Mon is a multi-phase, multi-channel, multi-function Ampere/Volt demand meter suitable for use in single-phase and three-phase applications.
- Multi-channel submetering - Up to 36 single-phase, 18 two-phase or 12 three-phase submeters in a single, compact device. Any combination of single-, two-, and/or three-phase loads can be monitored up to a total of 36 current inputs.
- 2-row, 16-character backlit LCD display for easy set-up and programming.
- Data recorders; programmable periodical data logs separate for each submetered point. Embedded programmable controller (4 control setpoints, programmable thresholds and delays) separate for each metered point. Event recorder for logging internal diagnostic events and setpoint operations.
- Time-Of-Use, 4 energy/demand registers x 4 tariffs, 4 seasons x 4 types of days, 8 tariff changes per day, easy programmable tariff schedule.
- Compatible with E-Mon Energy software via EZ7 protocol for automatic meter reading, energy billing and profiling.
- Supplied with Power Software for meter set up and power quality analysis. (requires RS-485 key for communication.)
- Current sensors available in both split & solid-core configurations for increased flexibility in installation. Current sensor leads can be extended up to 500 feet for remote installation. (Current sensors ordered separately. See Multi-Mon current sensor spec for details.)
- Communication options:
 - Modbus RTU via RS-485 communication (standard)
 - Modbus TCP/IP via Ethernet (optional)
- Easy field upgrading device firmware through any communication port.
- Optionally available pre-installed inside a JIC steel enclosure with lockable window panel and 3-phase voltage terminal block. Dimensions: 9.06" H x 23.62" W x 6.1" D
- Real Time Clock storage upon loss of power: 24 Hours minimum (1 Week typical.)
- 60 Hz operation.
- UL Listed for the US & Canada.
- Self power supply: 3-phase and neutral fed from the metered voltages.
- ANSI C12.20 Class 10/20 Class 0.5 Precision (Active Energy.)
- Compliant with ANSI and IEC specifications.
- Approvals: UL, CE, ISO, VNIIMS.



PowerSmart+ Essential Models

**PowerSmart+ Essential Meter
(Integrated 5 Amp current sensors for use with
existing 5 Amp output current transformers.)**

E-PS-E-RTU-5

**PowerSmart+ Essential Meter for
use with PowerSmart+ current sensors
(Ordered separately. See PowerSmart+ current
sensor spec for details.)**

E-PS-E-RTU-N

Options

Modbus TCP/IP communication via Ethernet-Add
suffix "-ETH" to the end of the model.
Example: E-PS-E-RTU-5-ETH

Wired cabinet option - Add suffix "-EWC" to
the end of the model.
Example: E-PS-E-RTU-5-EWC

Note: RS-485 Key required for communicating with Power Software.

Features

- Class 0.5S IEC 62053-22 four quadrant active and reactive energy polyphase static meter.
- Ampere/Volt demand meter with TrueRMS, power, power factor, neutral current, voltage and current unbalance frequency.
- Dual Panel mounting configuration for 4" round or 96x96 DIN new or retrofit installations.
- High precision 3-phase meter monitoring:
 - Voltage
 - Current
 - Power
 - Power Factor
 - Neutral Current
 - Energy
 - Demand
 - Frequency
 - Load Profile
 - Voltage/current unbalance
- 3.5" monochromatic LCD display with 240x128 dots resolution, adjustable update time, backlit and user defined brightness settings.
- LED bar graph showing percent load with respect to user-definable nominal load current.
- Supplied with E-Mon Power Software for meter set up and power quality analysis. (requires RS-485 key for communication.)
- Voltage and current THD, current TDD and K-Factor, up to 40th order harmonic.
- Voltage and current harmonic spectrum and angles.
- Real-time "scope mode" waveform monitoring capability.
- Simultaneous 6-channel one-cycle waveform capture at a rate of 64 samples per cycle.
- 3 voltage inputs and 3 current transformer-isolated AC inputs for direct connection to power line or via potential and current transformers.
- Current Sensor Options:
 - Available with integrated 5 Amp current sensors for use with existing 5 Amp output current transformers.
 - Available as a meter only configuration for use with PowerSmart+ current sensors. Current sensor leads can be extended up to 500 feet for remote installation (sold separately, see PowerSmart+ current sensor spec for details.)
- Standard 2-wire RS-485 communication port; Modbus RTU, DNP3 and ASCII communication protocols.
- Optional Ethernet 10/100BaseT port for Modbus TCP/IP communication.
- Optionally available pre-installed inside a JIC steel enclosure with lockable window panel and 3-phase voltage terminal block. Dimensions: 9.06" H x 23.62" W x 6.1" D
- Three-phase total and per phase energy measurements; active, reactive and apparent energy counters.
- Time-of-use, 4 totalization and tariff energy/demand registers x 8 tariffs, 4 seasons x 4 types of days, 8 tariff changes per day.
- Automatic daily energy and maximum demand profile log for total and tariff registers.
- 16 control setpoints; programmable thresholds and delays.
- 1-cycle response time.
- Non-volatile memory for long-term event and data recording.
- Event recorder for logging internal diagnostic events and setup changes. Two data recorders; programmable data logs on a periodic basis; automatic daily energy and maximum demand profile log.
- Auto-scroll option with adjustable page exposition time; auto-return to a default page.

Power Quality Meters

Features

- Class 0.2 four-quadrant multi-function 3-phase energy meter (TrueRMS, volts, amps, power, power factor, neutral current, voltage & current unbalance & frequency.)
- Easy-to-read 3-row bright LED display, adjustable update time, auto-scroll option with adjustable page exposition time and auto-return to a default page.
- LED bar graph showing percent load with respect to user-definable nominal load current.
- Supplied with E-Mon Power Software for meter set up and power quality analysis. (requires RS-485 key for communication.)
- Ampere/Volt/THD/TDD demand meter with advanced power quality features including embedded harmonic analyzer, voltage and current THD, current TDD and K-Factor, inter-harmonics THD, up to the 50th order harmonic.
- Real-time waveform capture and monitoring; simultaneous 6-channel 4-cycle capture at 128 samples per cycle.
- 3 voltages and 3 current transformer-isolated AC inputs for direct connection to power line or via potential and current transformers.
- Voltage and current harmonic spectrum and angles.
- Current Sensor Options:
 - Available with integrated 5 Amp current sensors for use with existing 5 Amp output current transformers.
 - Available as a meter only configuration for use with PowerSmart+ current sensors, Current sensor leads can be extended up to 500 feet for remote installation (sold separately, see PowerSmart+ current sensor spec for details.)
- Standard 2-wire RS-485 communication port; Modbus RTU, DNP3 and ASCII communication protocols.
- Optional Ethernet 10/100BaseT port for Modbus TCP/IP communication.
- Two digital inputs for monitoring external contacts, and receiving pulses from energy, water and gas meters. Two relay outputs for alarms and controls, and for output of energy pulses.
- Optionally available pre-installed inside a JIC steel enclosure with lockable window panel and 3-phase voltage terminal block. Dimensions: 14" H x 12" W x 8" D
- Time of Use (TOU), 8 totalization and tariff energy/demand registers x 8 tariffs, 4 seasons x 4 types of days, 8 tariff changes per day, easy programmable tariff schedule.
- Automatic daily profile for energy and maximum demand readings (total and tariff registers.)
- Embedded programmable controller; 16 control setpoints; programmable thresholds and delays; relay output control; 1/2 cycle response time.
- Event recorder for logging and internal diagnostics events, control events and I/O operations. 16 data recorders; programmable data logs on a periodic basis and on any internal and external trigger.
- Two waveform recorders; simultaneous 6-channel AC recording in a single plot; sampling rate of 32, 64 and 128 samples per cycle; 20 pre-fault cycles; up to 30 seconds of continuous recording at a rate of 32 samples per cycle.
- EN50160 Power Quality recorder (EN50160 compliance statistics, EN50160 harmonics survey statistics, onboard power quality analyzer, rogrammable thresholds and hysteresis; ready-for-use reports.)



PowerSmart+ Advanced Models

**PowerSmart+ Advanced Meter
(Integrated 5 Amp current sensors for use with
existing 5 Amp output current transformers.)**

E-PS-A-RTU-5

**PowerSmart+ Advanced Meter for
use with PowerSmart+ current sensors
(Ordered separately. See PowerSmart+ current
sensor spec for details.)**

E-PS-A-RTU-N

Options

Modbus TCP/IP communication via Ethernet-Add
suffix "-ETH" to the end of the model.
Example: E-PS-A-RTU-5-ETH

Wired cabinet option - Add suffix "-AWC" to
the end of the model.
Example: E-PS-A-RTU-5-AWC

Note: RS-485 Key required for communicating with
Power Software.



PowerSmart⁺ Socket Models

**PowerSmart⁺ Socket Meter
Form 9S, Three-Phase, 60 Hz
120-277V AC +/- 20%**

E-PS-S-SV-RTU

**PowerSmart⁺ Socket Meter
Form 9S, Three-Phase, 60 Hz
57.73-120V AC +/- 20% (Instrument
rated, used with PTs & CTs)**

E-PS-S-HV-RTU

Options

Modbus TCP/IP communication via Ethernet-Add
suffix "-ETH" to the end of the model.

Example: E-PS-S-HV-RTU-ETH

Note: RS-485 Key required for communicating with Power Software.

Features

- Precise Class 0.2 Active Energy & Power demand meter with easy to read 4" graphical display, multiple tariffs and Time Of Use (TOU), transformer and line losses, unique anti-tampering & self-test functions.
- Form 9S configuration for new or retrofit socket-style installation.
- State of the art power quality recorder (onboard PQ analyzer according to EN50160, programmable thresholds with hysteresis; ready-to-use reports, sags/swells, interruptions, frequency variations, flicker, temporary over voltages, transient over voltages, voltage unbalance, harmonic and interharmonic voltages.)
- Programmable controller (32 control set points, OR/AND logic, extensive triggers, programmable thresholds and delays, relay control, event-driven data recording.)
- Supplied with E-Mon Power Software for meter set up and power quality analysis. (requires RS-485 key for communication.)
- High-Class 3-phase demand power meter (amps, volts, harmonic demands, TrueRMS of volts and amps, powers, power factors and neutral current.)
- Harmonic analyzer (to 63th harmonic volts and amps, power harmonics and power factor, phasor, symmetrical components.)
- Event recorder for logging internal diagnostics events, control events and I/O operations. Digital fault recorder (onboard fault detector-programmable fault, up to 50 Amps fault currents, zero-sequence currents and volts, current and volt unbalance, under-voltage, neutral current.
- PowerSmart⁺ Socket meter uses flash memory for storing device firmware that allows future upgrading of the device without replacing any hardware component. The new features can be easily added to your device by simply replacing the firmware through a local RS-232/RS-485, USB or Ethernet port.
- Non-volatile memory - 16 MB for energy & tariff registers logging, EV-PQ-WV log.
- Isolated three-phase power supply unit from the measured voltage inputs, according to the voltage measurement input range:
 - Low range measurement input nominal rating: 57.7V AC to 120V AC (L-N)
 - High range measurement input nominal rating: 120V AC to 277V AC (L-N)
- Four fast waveform recorders; selectable AC sampling rate of 32-1024 samples per cycle, 20 pre-fault cycles, 1-ms resolution for digital inputs monitoring, up to 3 min. of continuous recording with an 8 MB onboard memory at a rate of 32 samples per cycle.
- Sixteen fast data recorders (from 1/2 cycle RMS to 2 hour RMS envelopes, up to 20 pre-fault cycles, programmable data logs on a periodic basis and on any internal and external trigger.)
- 16 programmable timers from 1/2 cycle to 24 hours for periodic recording and triggering operations on a time basis.
- Built-in (2) digital optically isolated fast inputs and 1 KYZ relay output.
- Communication capabilities:
 - Standard: On-board Infrared port, isolated RS-485 port and USB device port for Modbus RTU/ASCII and DNP3.0 protocols.
 - Optional: Ethernet 10/100Base-T port for Modbus TCP/IP or DNP3.0 TCP protocols.
- Approvals: UL/CSA 61010-1: ANSI C12.20: Class 10/20, IEC 62053-22: Class 0.25.

Third-Party Products

Electric, Gas, Water, Steam, BTU, fuel & compressed air

BTU Meters w/Pulse Output

A wide variety of BTU meters are available for tracking the energy used in chilled and heating water loop systems. A BTU meter consists of 6 components; 1-flow meter (with installation kit), 2-temperature probes, 2-temperature wells that the temp probes fit into and a BTU calculating unit. The BTU calculating unit comes standard with a pulse output for interfacing with external data recorders. Modbus, BACnet, LonWorks, N2 and other communications are also available for interfacing with EMS/BMS. The flow meters are available in sizes from 3/4" to 72". Flow meters can handle a maximum fluid temperature of 248°F at up to 232 psi. Ultrasonic flow meters are also available for applications where non-invasive metering is required.



Cold Water Meters w/Pulse Output

Cold water meters are available in standard pipe sizes ranging from 5/8" up to 12". All cold water meters are equipped with a pulse output for interfacing with external interval data recorders for communication via Modbus, BACnet, LonWorks and EZ7 to E-Mon Energy software and/or EMS/BMS systems.

Multijet type meters are available in sizes up to 2". For higher flows starting at 1 1/2" heavy duty turbine meters are available. Ultrasonic flow meters are also available for applications where non-invasive metering is required.

All cold water meters are appropriate for potable water applications with a maximum temperature of no greater than 105°F and pressures up to 150 psi. All cold water meters are no-lead. Other meters are available for non-potable and specialty water metering applications such as industrial waste water, irrigation water, etc.

Hot Water Meters w/Pulse Output

Hot water meters are available in sizes from 1/2" up to 4". Meters up to 2" are available for standard temperature (up to 194°F at 150 psi), meter 3" and 4" are for temperatures up to 248°F at max 232 PSI. All meters are no lead. All hot water meters come equipped with a pulse output for interfacing with external interval data recorders for communication via Modbus, BACnet, LonWorks and EZ7 to E-Mon Energy software and/or EMS/BMS systems. Ultrasonic flow meters are also available for applications where non-invasive metering is required.

Steam Meters w/Pulse Output

Steam meters employ Vortex shedder technology and are available in both in-line and insertion type. The meters are available in sizes from 1/2" up to 8". The meters are supplied with a pulse output to interface with external data recorders for communication via Modbus, BACnet, LonWorks and EZ7 to E-Mon Energy software and/or EMS/BMS systems. The meter requires AC power to operate. The steam meters are available for standard temperature (-40 to 400°F) and for high temperature (-40 to 750°F), at a maximum pressure of 150 psi.

Gas Meters w/Pulse Output

Gas meters are available for loads from 250 CuFt/Hr (250,000 BTUs/Hr) up to 56,000 CuFt/Hr (56 million BTUs/Hr). The meter connection sizes range from a Sprague #1 up to 4". Meters up to 1 1/4" pipe size are diaphragm meters. Larger size meters are Fluidic Oscillation type meters which have no moving parts. All gas meters include connection hardware kits and pulse output to interface with external interval data recorders for communication via Modbus, BACnet, LonWorks and EZ7 to E-Mon Energy software and/or EMS/BMS systems. These meters are traditionally for natural gas and propane use, although they can be used to meter other types of gases.

For other sizes and configurations of gas, water, steam and BTU meters contact E-Mon at (800) 334-3666 or email info@emon.com.

E-Mon D-Mon Split-Core Current Sensors

Class 1000, 2000, 3200, 3400, 5000 & Green Meter Current Sensor Specifications

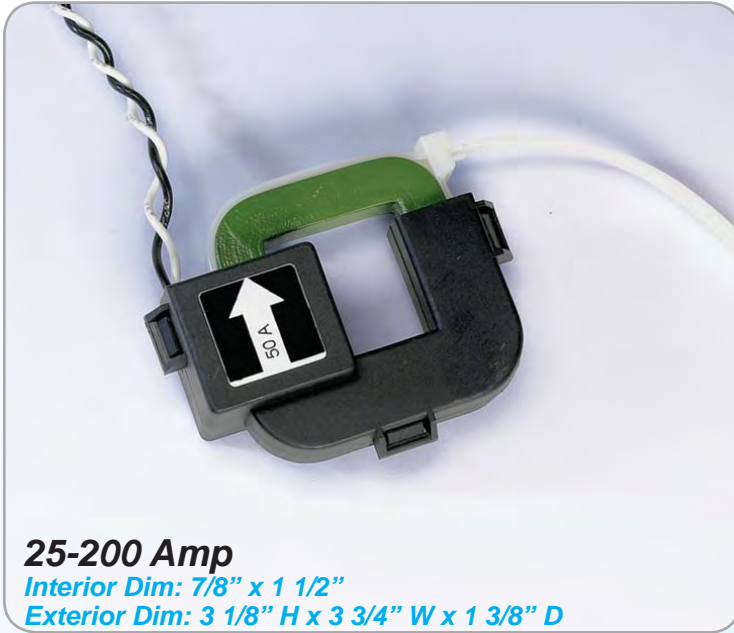

25-200 Amp

Interior Dim: 7/8" x 1 1/2"

Exterior Dim: 3 1/8" H x 3 3/4" W x 1 3/8" D

400 Amp

Interior Dim: 1 1/2" x 2 3/4"

Exterior Dim: 4 3/8" H x 3 3/4" W x 1 3/8" D

800-1600 Amp

Interior Dim: 3 1/4" x 4 1/2"

Exterior Dim: 5 3/4" H x 5 3/8" W x 1 3/8" D

3200 Amp

Interior Dim: 5 7/16" x 7 7/8"

Exterior Dim: 9 1/4" H x 7 7/8" W x 1 3/8" D

Split-Core Current Sensor Models

Model	Amperage	Interior Dim.
CS25	25 Amp	7/8" x 1 1/2"
CS50	50 Amp	7/8" x 1 1/2"
CS100	100 Amp	7/8" x 1 1/2"
CS200	200 Amp	7/8" x 1 1/2"
CS400	400 Amp	1 1/2" x 2 3/4"
CS800	800 Amp	3 1/4" x 4 1/2"
CS1600	1600 Amp	3 1/4" x 4 1/2"
CS3200	3200 Amp	5 7/16" x 7 7/8"

Notes:

The above split-core current sensors are supplied with E-Mon D-Mon Class 1000, 2000, 3200, 3400, 5000, Green and Green Net meters.

Current sensors can be installed up to 2,000 feet away from meter (500 feet for Class 3200, 3400, 5000 and Green Net.) Leads supplied are 3' in length and can be extended using #14-22 AWG wire (stranded/twisted not required.) See local electrical codes for proper sizing.

When paralleling current sensors, the meter reading must be multiplied by the number of sets of sensors in parallel.

Solid-core current sensors available in 100 & 200 amp. Specify when ordering.

Din-Mon Current Sensors

Current Sensor Specifications

Din-Mon Current Sensors **MUST** be used with Din-Mon D2 & D5 series meters. These current sensors cannot be used with any other E-Mon D-Mon product.

Note: Din-Mon sensor models below are sets of (3) sensors. To order by the piece, replace the “S” at the beginning of the model with “P.” Example: P100A-SP-333V

0.333 Volt Split-Core Current Sensors (Standard sensors supplied with Din-Mon meters.)



0.333 Volt Din-Mon Split-Core Current Sensor Models

Model	Amperage	Interior Dim.
S100A-SP-333V	100 Amp	0.75" H x 0.75" W x .06" D
S200A-SP-333V	200 Amp	1.25" H x 1.25" W x 1" D
S400A-SP-333V	400 Amp	1.25" H x 1.25" W x 1" D
S800A-SP-333V	800 Amp	2" H x 3" W x 1.2" D

100 mA Split-Core Current Sensors (Optional sensors available for Din-Mon meters.)



100 mA Din-Mon Split-Core Current Sensor Models

Model	Amperage	Interior Dim.
S200A-SP-100MA	200 Amp	1.25" H x 1.25 W x 1" D
S400A-SP-100MA	400 Amp	1.25" H x 1.25" W x 1" D
S800A-SP-100MA	800 Amp	2" H x 3" W x 1.2" D

0.333 Volt Solid-Core Current Sensors (Standard sensors supplied with Din-Mon meters.)



0.333 Volt Din-Mon Split-Core Current Sensor Models

Model	Amperage	Interior Dim.
S100A-SC-333V	100 Amp	0.75" Diameter, 0.8" D
S200A-SC-333V	200 Amp	0.75" Diameter, 0.8" D

100 mA Solid-Core Current Sensors (Optional sensors available for Din-Mon meters.)



0.333 Volt Din-Mon Split-Core Current Sensor Models

Model	Amperage	Interior Dim.
S100A-SC-100MA	100 Amp	0.75" Diameter, 0.8" D
S200A-SC-100MA	200 Amp	0.75" Diameter, 0.8" D

Multi-Mon & PowerSmart+ Current Sensors

Current Sensor Specifications

Multi-Mon & PowerSmart+ current sensors can only be used with Multi-Mon & PowerSmart+ meters. Split and solid core sensors are ordered by the piece and are not compatible with other styles of E-Mon D-Mon meters.

All sensors are rated for 600 V and supplied with 2.5 meter cable length which can be extended up to 500 feet for remote installation.

100 Amp Sensors - Order By Piece

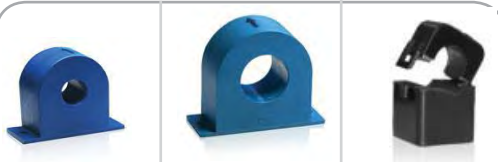

Model	E-MPS-100-12-SCS	E-MPS-100-23-SCS	E-MPS-100-16-SPL
Inside Dim.	12mm/0.47"	23mm/0.9"	16mm/0.63"
Core	Solid	Solid	Split
Accuracy	0.1%	0.1%	0.5%
Burden	0.2 VA	0.2 VA	0.2 VA
Weight	0.34 lbs	0.45 lbs	0.23 lbs

200 Amp Sensors - Order By Piece



Model	E-MPS-200-24-SPL
Inside Dim.	24.5x23.1mm/0.96x0.9"
Core	Split
Accuracy	0.5%
Burden	0.2 VA
Weight	0.34 lbs

400 Amp Sensors - Order By Piece



Model	E-MPS-400-26-SCS	E-MPS-400-43-SPL
Inside Dim.	26mm/1.02"	43.2X33mm/1.7X1.3"
Core	Solid	Split
Accuracy	0.1%	0.5%
Burden	0.2 VA	0.2 VA
Weight	0.47 lbs	1 lbs

800 Amp Sensors - Order By Piece



Model	E-MPS-800-50-SPL
Inside Dim.	50x80mm/1.9x3.1"
Core	Split
Accuracy	0.5%
Burden	0.2 VA
Weight	2.2 lbs

1200 Amp Sensors - Order By Piece



Model	E-MPS-1200-121-SPL
Inside Dim.	121x80mm/4.7x3.1"
Core	Split
Accuracy	0.5%
Burden	0.2 VA
Weight	3.3 lbs

E-Mon Energy Automatic Meter Reading System

Software System For Energy Statements, Tenant Billing, Graphing & Profiling of Energy Data

Ideal for new and retrofit applications, E-Mon Energy automatic meter reading systems allow users to accurately monitor interval energy data for a variety of applications including tenant billing/allocation, departmental allocation, common area management, demand/energy analysis, equipment maintenance programs, M & V for LEED certification and other green building initiatives.

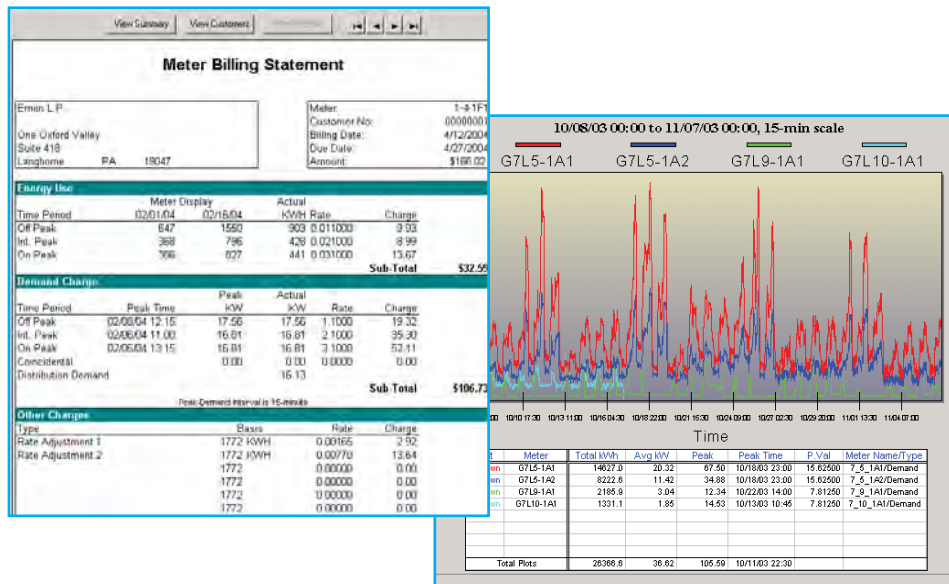

E-Mon Energy monitors E-Mon D-Mon electric submeters either on-site or off-site via a variety of industry standard communication methods and transmits data back to a central computer for generating profiles, graphs and tenant statements of energy usage.

Accurate and timely snapshots of your facility's energy use are essential to support energy management initiatives. With E-Mon Energy software, you can combine all of your utility service data — including gas, electric, water and steam — into a single location to see how, when and where your facility is using energy. In addition, E-Mon Energy allows you to go beyond simple identification of energy use, you can easily and accurately allocate energy costs based on actual usage by department, cost center, tenants or equipment.

In addition to usage statements, E-Mon Energy also provides the graphs and charts needed to identify potential energy saving opportunities in a facility. With the ability to identify exactly when and where usage takes place, a facility manager is now able to better manage and maintain building equipment and adjust timing of energy loads to reduce overall energy usage.

Features include:

- Software provides graphical profiling for 5-, 15-, 30- or 60-minute sampling rates and generates analytical charts and graphs of energy and demand usage.
- Software generates and prints itemized electric bills (using coincidental peak demand date and time.) Software will generate bills from user-specific time periods via profile data (you need not be present to generate meter readings.)
- Reads all E-Mon D-Mon meters via IDR and Smart meters directly via EZ-7 communication protocol.
- Reads gas, water, BTU, steam and other third-party meters via IDR for billing purposes and graphical display of usage.
- Exports data to spreadsheets for analysis (.CSV files) and to MV-90 systems (.hhf files.)

Metering System Overview

Web-Mon Web-Enabled Energy Monitoring System Energy & Carbon Footprint Dashboards Via The Internet

Accurate, timely snapshots of energy usage and carbon footprint data are critical for today's progressive energy management initiatives. In response, E-Mon's Web-Mon product family provides a user-friendly web interface that lets you view live energy data, charts and graphs via any standard Internet browser without unneeded extras or costly custom programming.

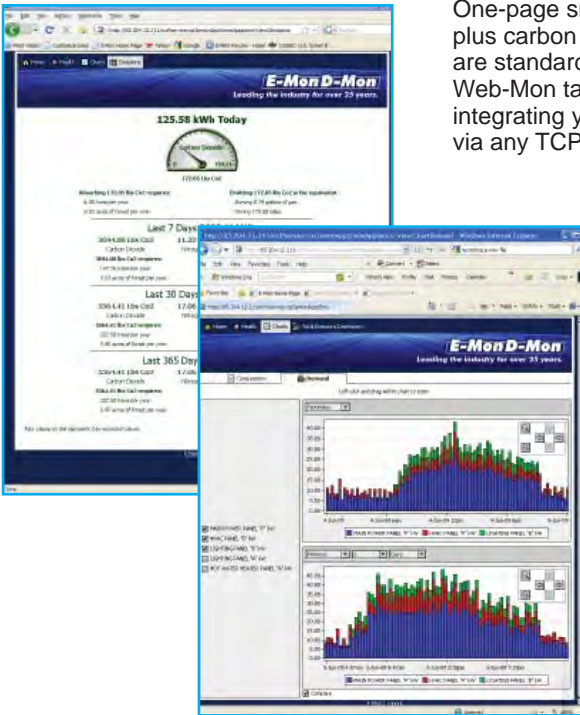

One-page snapshots of real-time and historical energy consumption and demand, plus carbon footprint displays of estimated CO₂, NO_x, SO₂ and other parameters, are standard features. Designed for single building and multi-facility applications, Web-Mon takes one-click energy management to the next level by automatically integrating your distributed metering infrastructure into real-time meter dashboards via any TCP/IP local or wide area network.

Web-Mon directly communicates over your facility's existing IP backbone with remote E-Mon D-Mon smart meters and up to three connected pulse-output utility meters per Web-Mon device. In addition to single-building scenarios, typical campus-style applications include schools & universities, government facilities, medical complexes, business parks, military bases and other commercial, industrial and institutional users.

The ability to view usage on-demand either on-site or remotely allows energy managers and others to easily stay on top of energy conservation programs, green building initiatives or overall efficiency analysis. Whether the need is for one-page dashboards, energy profiles or raw interval data, Web-Mon is the smart solution for any single or multi-facility energy monitoring and management application requiring high-impact visual presentment of electricity, gas, water and other metered parameters.

Integration With Other Building Management/AMR Systems Communication Protocols Allow Easy Interface to Existing Systems

E-Mon has led the submetering industry for over 30 years with advanced technology and innovative and flexible metering solutions. This includes the ability to interface our metering products with other building management and automatic meter reading systems. Our line of Smart meters and IDRs allow energy users and facility managers to leverage their E-Mon D-Mon submeters and integrate the interval energy data to their existing building management systems via industry standard protocols. Built-in communication capabilities allows you to choose the system that best fits your facility's energy needs. E-Mon's smart meters and IDRs provide dual-communication capabilities so that you can not only utilize your existing BMS system for energy management, but at the same time utilize E-Mon Energy AMR software for billing, allocation and graphic profiling of your energy consumption. No submetering line offers as much flexibility as E-Mon D-Mon.

Communication Protocols via Smart Meters & IDRs include:

- EZ7 (E-Mon Energy) via RS-485, telephone and/or Ethernet
- ModBus RTU
- BACnet MS/TP
- LonWorks TP/FT-10
- Modbus TCP/IP
- BACnet IP
- Pulse Output



E-Mon Energy Automatic Meter Reading Software

E-Mon Energy Metering System



E-Mon Energy Software Models

EMONENERGYSW
EMONENERGYSW-SERVER

E-Mon Energy software packages include USB Key (RS-485 to USB Converter.)

Meter Billing Statement

From L.P.	1-4-199
From Contract No.	10000000
From A/R	Billing Date: 4/12/2004
Longline	From Date: 4/27/2004
	Amount: \$168.02

Energy Use	Month Charge	Actual	Rate	Charge
Time Period	02/01/04	02/01/04	Rate	Charge
Off Peak	647	1294	0.00000	0.00
Off Peak	366	732	0.00000	0.00
On Peak	386	772	0.00000	0.00
				Sub Total
				\$168.02

Demand Charge	Peak	Actual	Rate	Charge
Time Period	Peak Time	Peak	Rate	Charge
Off Peak	02/01/04 12:15	17.56	1.000	17.56
On Peak	02/01/04 11:00	16.81	2.1000	35.30
On Peak	02/05/04 13:15	16.81	1.5000	25.21
Commodity	0.00	0.00	0.0000	0.00
Distribution Demand				
				Sub Total
				\$168.73

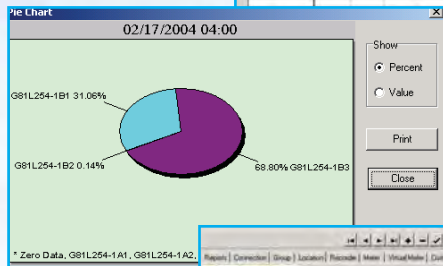
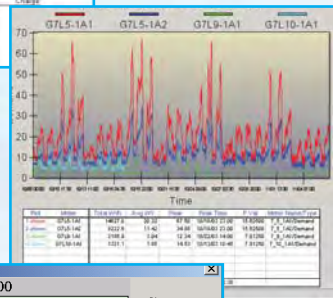

TDI Schedule

Season	Start Date	End Date	From	To	From	To
Season 1	10/01/03	09/30/04	08:00	18:00	08:00	18:00
Season 2	10/01/04	09/30/05	08:00	18:00	08:00	18:00
Season 3	10/01/05	09/30/06	08:00	18:00	08:00	18:00
Season 4	10/01/06	09/30/07	08:00	18:00	08:00	18:00

Features

- E-Mon Energy operates with computers having the following specifications:
 - OS: Windows 2000, 2003, XP, 7 or 8
 - RAM: 4 GB
 - Hard Disk: 100 GB
 - Ethernet: Static IP address with port 12005
- E-Mon Energy software available for both single-license and server-license applications.
- Graphic profiling provides analytical charts and graphs with demand profiling for 5-, 15-, 30- or 60-minute sampling rates.
- Generate and print itemized electric bills (using coincidental peak demand date and time). Software will generate bills from user-specified time periods via profile data (you need not be present to generate meter readings.)
- Reads up to 8 time periods, 4 seasons and multiple holidays for time-of-use (TOU) monitoring.
- Reads E-Mon D-Mon meters, either on-site or off-site, via telephone modem, Ethernet or a directly connected computer.
- Reads all E-Mon D-Mon meters via IDRs and E-Mon D-Mon Smart meters directly (when ordered with EZ7 protocol). Can also read gas, water, BTU and steam meters via IDR for billing purposes and graphical display of usage.
- Exports data to spreadsheets for analysis (*.csv files).
- Exports data to MV-90 system (*.hhf files).
- Optional modems can be used with E-Mon Energy allowing meters to be read anywhere in the world where telephone or cellular service is available.
- Meter reading and billing services are available for both E-Mon D-Mon and utility-type meters.

E-Mon Energy Sample Graph & Billing Statement

E-Mon Energy Metering System

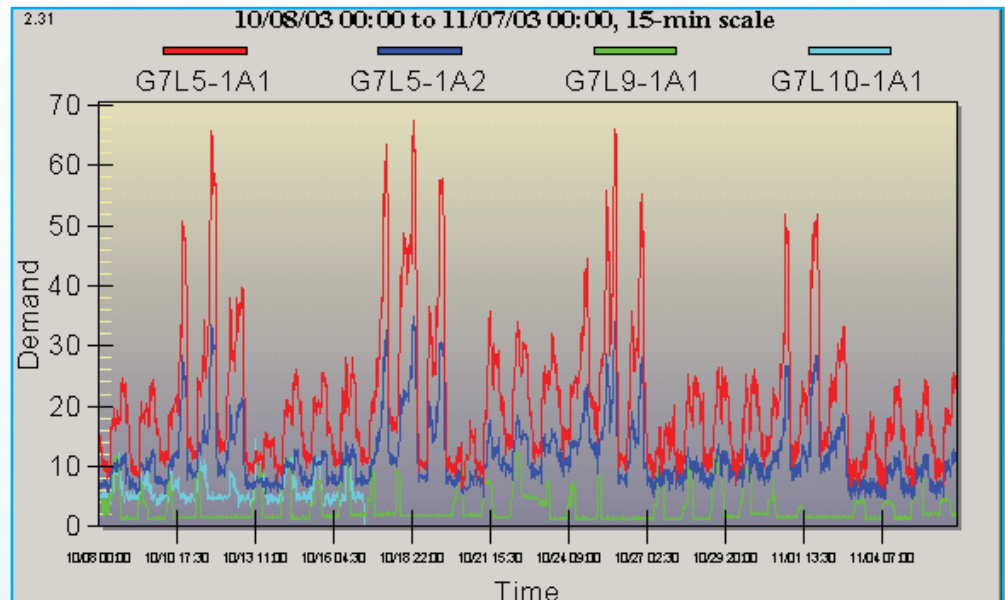

View Summary View Customers View Meters [Navigation Buttons]

Meter Billing Statement

Emon L.P.
 One Oxford Valley
 Suite 418
 Langhorne PA 19047

Meter: 1-4-1F1
 Customer No: 00000001
 Billing Date: 4/12/2004
 Due Date: 4/27/2004
 Amount: \$166.02

Peak Time	P.Val	Meter Name/Type
1/18/03 23:00	15.62500	7_5_1A1/Demand
1/18/03 23:00	15.62500	7_5_1A2/Demand
2/22/03 14:00	7.81250	7_9_1A1/Demand
1/13/03 10:45	7.81250	7_10_1A1/Demand
1/11/03 22:30		

Time Period	Meter Display		Actual		Charge
	02/01/04	02/16/04	KWH	Rate	
Off Peak	647	1550	903	0.011000	9.93
Int. Peak	368	796	428	0.021000	8.99
On Peak	386	827	441	0.031000	13.67
Sub-Total					\$32.59

Time Period	Peak Time	Peak		Actual		Charge
		KW	Rate	KW	Rate	
Off Peak	02/08/04 12:15	17.56	1.1000	17.56	1.1000	19.32
Int. Peak	02/06/04 11:00	16.81	2.1000	16.81	2.1000	35.30
On Peak	02/06/04 13:15	16.81	3.1000	16.81	3.1000	52.11
Coincidental		0.00	0.0000	0.00	0.0000	0.00
Distribution Demand				16.13		
Sub-Total					\$106.73	

Peak-Demand Interval is 15-minute

Type	Basis	Rate	Charge
Rate Adjustment 1	1772 KWH	0.00165	2.92
Rate Adjustment 2	1772 KWH	0.00770	13.64
	1772	0.00000	0.00
	1772	0.00000	0.00
	1772	0.00000	0.00
	1772	0.00000	0.00

IDR (Interval Data Recorder)

E-Mon Energy Metering System



Features

- Advanced scrolling 4-line display showing:
 - kWh for each meter connected to the IDR
 - Real-time load for each meter connected to the IDR
- On-board set-up option for:
 - IP address
 - Date/time
 - ID codes for EZ7, Modbus & BACnet
- Standard IDR (RJ Jacks) reads & records up to 8 or 16 E-Mon D-Mon electric meters. (Class 1000 & 2000 meters)
- IDR-8 ST (screw terminal) model can accept contact closure type pulse inputs from other types of meters (water, gas, BTU, steam, etc.)
- Built-in RS-485 communication capability supports up to 52 Class 3200, 3400 and 5000 meters and/or IDR interval recorders (not to exceed 52 devices/channel). Cabling can either be daisy-chain or star configuration, 3-cond., 18-22 AWG, up to 4,000 cable feet total per channel.
- Built-in RS-485 and Ethernet communications, optional telephone modem available.
- Protocols:
 - EZ7
 - Modbus TCP/IP
 - BACnet IP*
 - Modbus RTU
 - BACnet MS/TP*
 - LonWorks TP/FT-10
- Data stored in 15-minute intervals for up to 72 days or 5-minute intervals for up to 24 days. Maintains data in a first-in, first-out format.
- Reads usage and reads demand in 15, 30 or 60-minute kW periods (15-minute standard.)
- 120V power supply required and included with all IDRs.
- Maintains data in case of power outage.
- Industrial grade JIC steel enclosure (standard) with padlocking hasp & mounting flanges for indoor installation and three 1 1/16" knockouts (3/4" conduit) on bottom of enclosure.
- Optional MMU style enclosure. (can be factory installed in MMU Multiple Meter Unit cabinets with meters.)
- FCC Approval.
- MV-90 compatible (with EZ7 only.)

IDR Models

Standard Configuration

EIDR-8-J*RJ (Up to 8 meters)
EIDR-16J*RJ (Up to 16 meters)

IDR Screw Terminal Option for interface to third-party metering products

EIDR-8-J*ST (Up to 8 meters)

Optional Enclosure

IDRs are supplied standard with JIC steel enclosure for indoor installation. For optional enclosure replace the first "J" in the model with optional enclosure specification.

Specification M - MMU Configuration (ex. EIDR-8-M04ST)

Communication Protocol & Option Packages

Specify protocol package when ordering all meters.
Replace * in model number with protocol package specification below.

RS-485 Port		Specify
EZ7	EZ7 Ethernet	01
Modbus RTU	EZ7 Ethernet	02
BACnet MS/TP	EZ7 Ethernet	03
EZ7	Modbus TCP/IP	04
EZ7	BACnet IP	05
Modbus RTU	Modbus TCP/IP	06
LonWorks TP/FT-10	EZ7 Ethernet	07
LonWorks TP/FT-10	Modbus TCP/IP	08
EZ7 w/Telephone Modem	EZ7 Ethernet	09
EZ7 w/Telephone Modem	Modbus TCP/IP	10
EZ7 w/Telephone Modem	BACnet IP	11

E-Mon Energy System Configuration

E-Mon Energy Metering System

On-Site Monitoring with RS-485

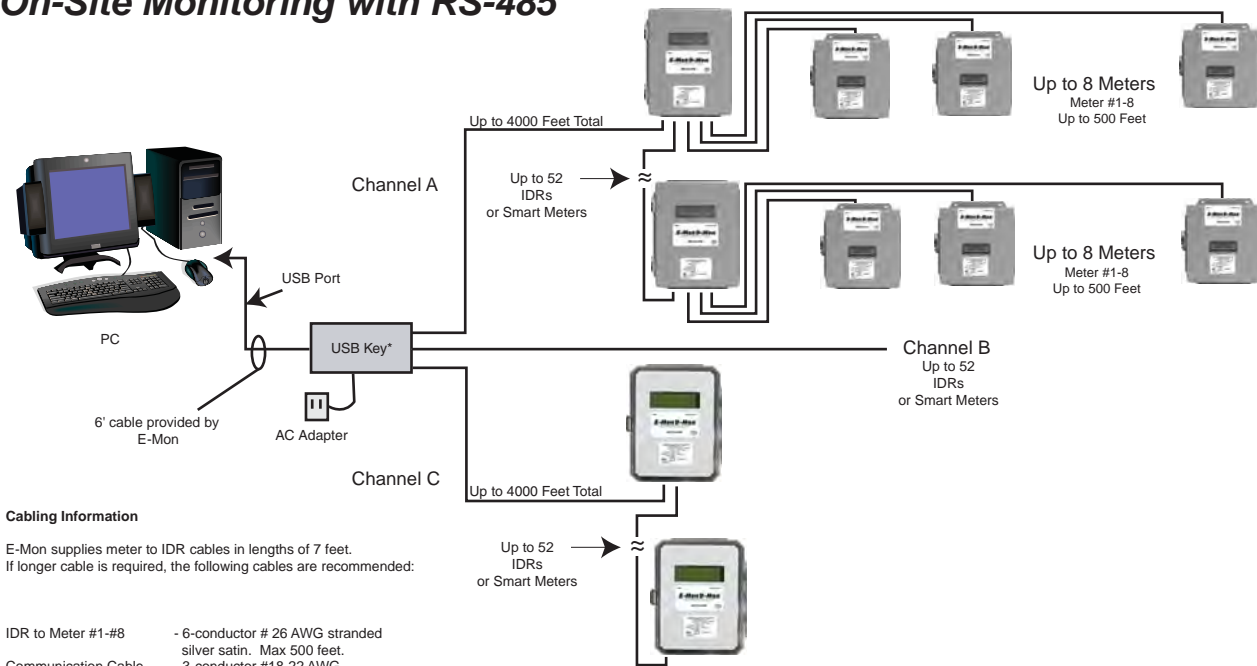

Cabling Information

E-Mon supplies meter to IDR cables in lengths of 7 feet.
If longer cable is required, the following cables are recommended:

IDR to Meter #1-#8 - 6-conductor # 26 AWG stranded silver satin. Max 500 feet.
Communication Cable - 3-conductor #18-22 AWG

Ethernet cable type 50060341-001, RS-485 cable BELDEN 1120A cable or equivalent

*** NOTE: For computers without RS-232 input, standard USB Key supports one channel, up to 52 devices. Multiple USB keys may be used for additional channels.**

Off-Site Monitoring with RS-485

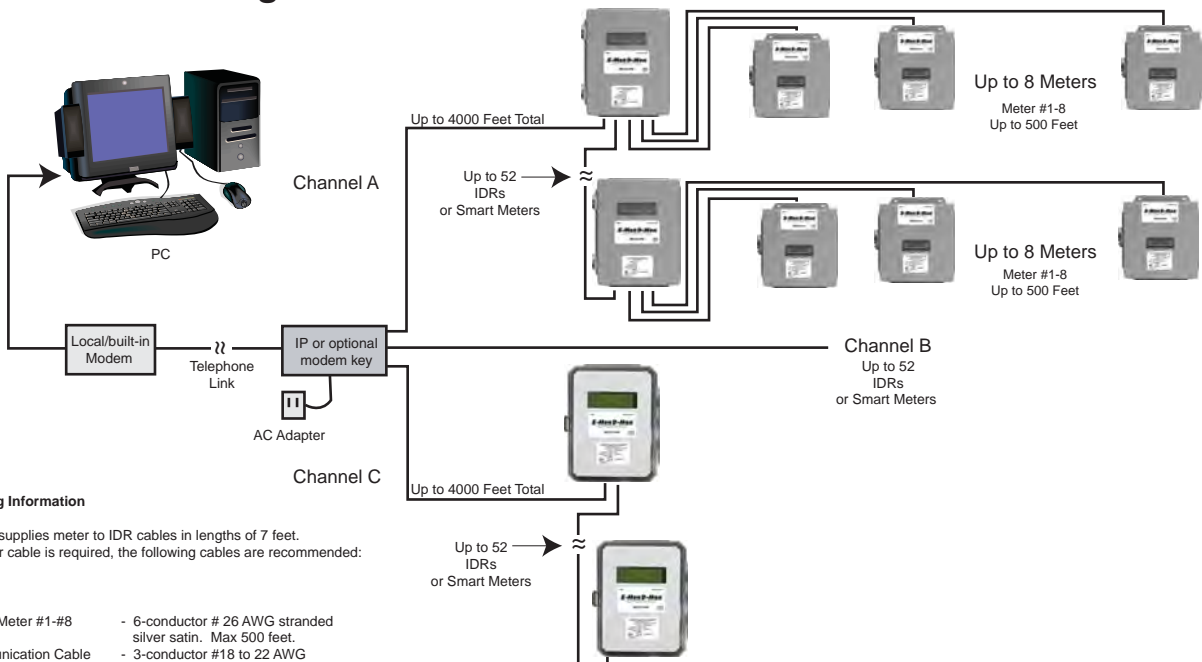

Cabling Information

E-Mon supplies meter to IDR cables in lengths of 7 feet.
If longer cable is required, the following cables are recommended:

IDR to Meter #1-#8 - 6-conductor # 26 AWG stranded silver satin. Max 500 feet.
Communication Cable - 3-conductor #18 to 22 AWG

Ethernet cable type 50060341-001, RS-485 cable BELDEN 1120A cable or equivalent

**Communication keys required for E-Mon Energy AMR system.
Visit www.emon.com for more information.**

Web-Mon (Web Enabled Energy Monitor)

Web-Mon Metering System

Features

- Provides users with one-page snapshots of historical and real-time energy usage data accessible via any standard web-browser. Easy-to-read energy dashboards include kWh, kW demand as well as carbon footprints of estimated CO₂, NO_x, SO₂ and other parameters.
- The ability to manage energy consumption is just a click away. Energy data is displayed for various time periods including today, last 7 days, last 30 days and last 365 days.
- Advanced meter functions can be displayed real-time for kW load, Volts & Amps by Phase, Power Factor and more!
- User friendly, password protected web user interface allows users to view live energy data, charts and graphs via any standard web browser.
- Interface with up to 24 metering points including E-Mon D-Mon meters or other electric, water, gas, steam and BTU meters.
 - E-Mon D-Mon Smart meters and other serial devices are connected via RS-485 daisy chain connection, up to 4,000 feet total.
 - Class 1000 & 2000 meters (PIM required for meters manufactured prior to 2012) and other pulse enabled meters (i.e. water, gas, etc.) connect to optional 8-port I/O modules (up to 3 modules per Web-Mon) and can be up to 200 feet from Web-Mon.
- Export data to E-Mon Energy software or .csv files for interface with other software packages.
- Internal memory stores up to 5 years of daily kWh consumption and peak demand and up to 60 days of 15-minute interval data.
- Ethernet connection to internet supports static IP address.
- JIC steel enclosure standard. Available without enclosure for installation into existing MMU cabinets or third-party enclosures.
- Web-Mon units can be ordered with E-Mon meters in MMU cabinets and shipped to you pre-configured as a complete metering package.
- Web-Mon includes AC adapter to power unit. Optional Din Rail power supply option available.
- Agency listings include UL916, CUL Listed to Canadian Standards Assoc. (CSA) C22.2 No 205-M1983 "Signal Equipment," CE, FCC part 15 Class A, C-Tick (Australia).



Web-Mon Models

Web-Mon

Includes two ethernet ports, one RS-232 port & one RS-485 port, JIC steel enclosure and AC power supply.

For Web-Mons without enclosure, add suffix "MMU" to end of the model. (ex. Web-MonMMU)

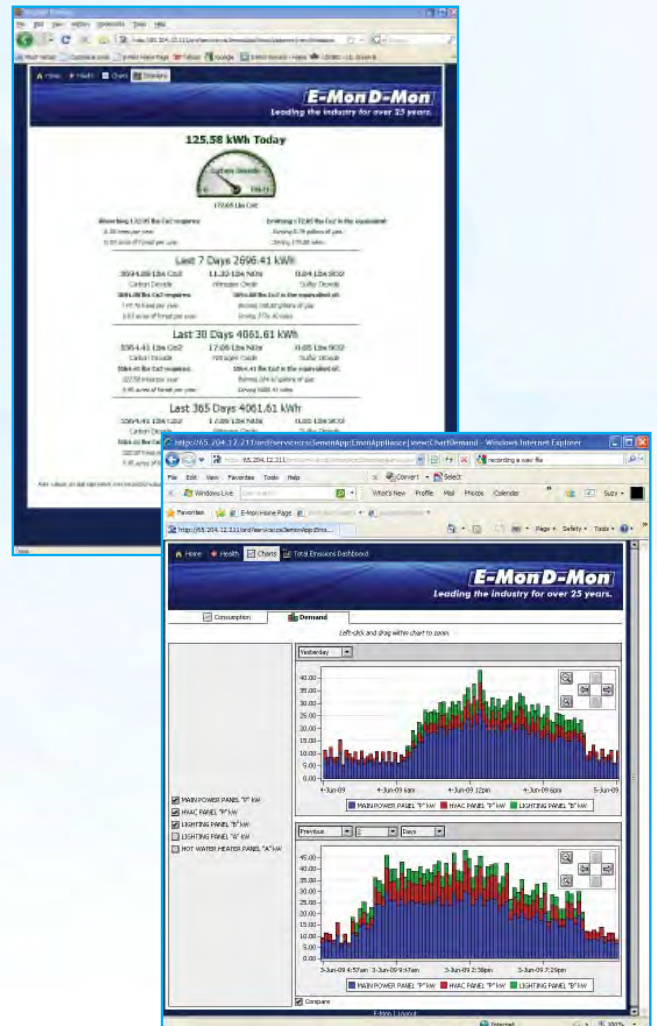

Web-Mon Energy System Configuration & Dashboard Samples

Web-Mon Metering System

Web-Mon Configuration - Pulse Connection

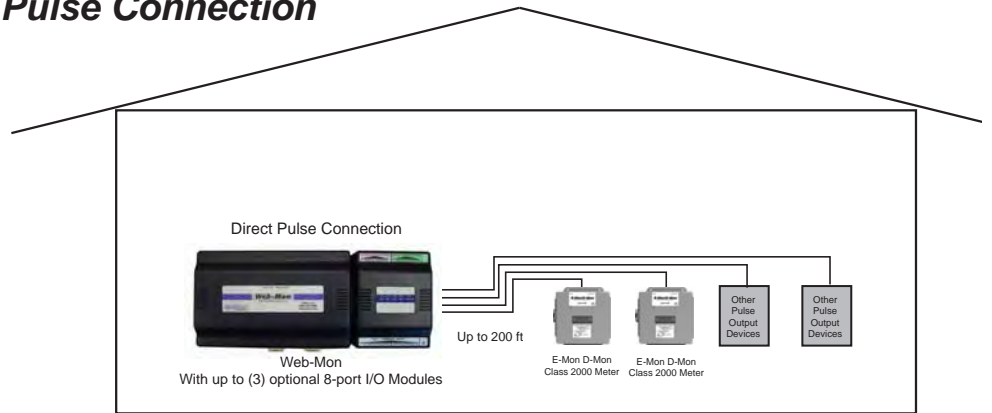

Metering Services

As more and more tenants demand actual energy usage data and the ability to manage energy consumption, property managers are turning to submetering to correctly assess energy usage. However, in areas where multi-tiered TOU (Time of Use) rate structures prevail, expert help may be required.

E-Mon provides outsourced meter reading and billing services to help property managers and tenants formulate a complete approach to accurate and reliable tenant energy use allocation and billing. E-Mon metering experts can review your facility and structure a solution that is most suitable for your application.

Services

A wide array of services are available for commercial, industrial and multi-tenant facilities including reading energy meters, generating tenant or departmental bills and creating usage profiles.

Services include:

- Daily meter reading
- Monthly tenant billing
- Landlord summary statements
- Utility bill consolidation (Gas, Water, Electric on one bill)
- Virtual metering
- Tenant & landlord help desk
- Move-in and move-out statements
- Historical data storage
- Individual tenant load profile graphs
- Automatic rate & tariff updates

Let E-Mon's experts assist you in implementing a metering solution that lets you:

- Save energy and the environment
- Market your building more competitively
- Increase occupancy and lower turnover
- Watch your property value escalate
- Increase your facility's profitability

Turn-Key Solutions

Optional turn-key solutions are available including:

- Project management
- Hardware procurement
- Installation through a network of certified installers
- System validation
- Meter reading
- Billing services

Meter Reading Technology

Meter reading services are performed remotely via automatic meter reading technology which increases accuracy and eliminates tenant disruptions.

Proven communication technologies include:

- Telephone modem
- Ethernet
- BAS Interface

For details on E-Mon's meter reading services call (800) 334-3666.

The Attune Energy Dashboard service provides extensive, real-time knowledge of your energy use in a user-friendly web-based solution from Honeywell. Analytics are provided as widgets in a graphical, intuitive web-based interface, which makes them easier to understand.

Visualizing energy data makes it easy to identify usage anomalies for corrective action. Trending and normalizing energy usage against weather data and various energy rates will provide the detail needed to make informed energy savings decisions and perform ongoing measurement and verification. Historical data storage allows users to review past usage and reports to project future energy consumption and trending.



Metering Solutions

The customizable dashboards provide immediate access to all of your utility meter data; including electric, gas, water and steam to provide you with a complete, customized view of your facility's energy usage.

Connectivity

Energy data is collected from site meters and transmitted to the Attune cloud for processing, storage and display. Connectivity is provided via the industry standard Modbus TCP/IP communication protocol.

Customizable User Displays

Each site has a unique customizable consumption display which includes a variety of widgets, graphs and charts showing energy consumption data for electric, gas, water, fuel oil and/or steam. Widgets include:

- Building Profile
- Site Information
- Electricity Cost
- Utility Tariff Pricing
- Building Operating Schedule
- Load Distribution
- CO2 Equivalent
- Benchmarking Analysis
- Electric, Gas & Water Trends
- Electric, Gas & Water Gauges
- Electric by Square Foot
- Available in 9 Languages
- Weather Information & Degree Days

Report Generation

The reporting feature of the Attune Energy Dashboard Service allows users to create CSV file exports. Reports can include outside temperature, demand, previous period and relative humidity by hour, week, day and

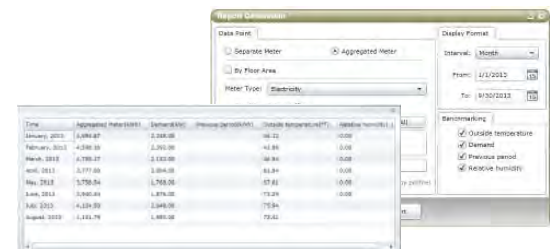

E-Mon D-Mon Meter Installation Overview

Reference Guide

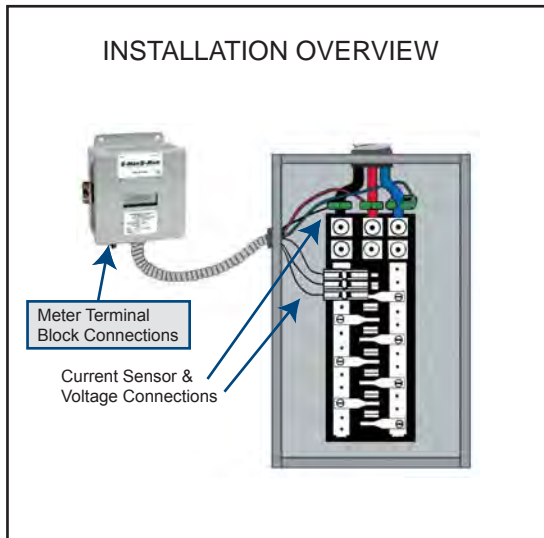

3-PHASE, 3-WIRE OR 3-PHASE, 4-WIRE INSTALLATION DIAGRAM

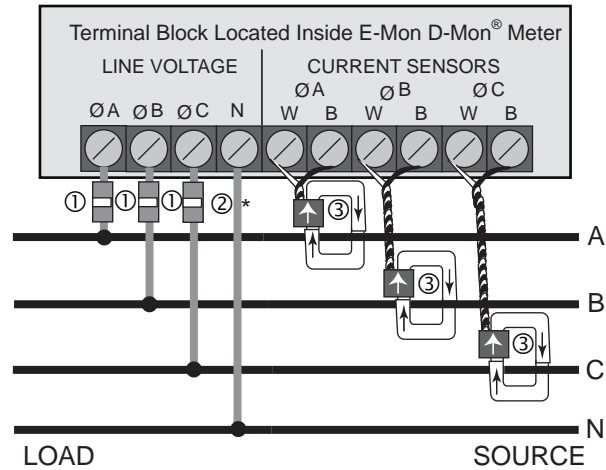

1-PHASE, 2-WIRE 120 or 277 VOLT INSTALLATION DIAGRAM (Class 1000 Series Only)

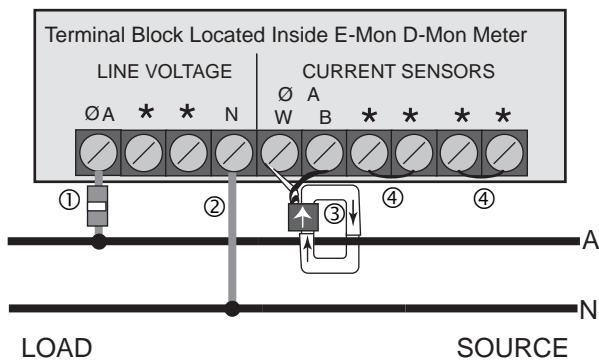

SINGLE-PHASE, 3-WIRE 120/240, 120/208 or 480 VOLT INSTALLATION DIAGRAM

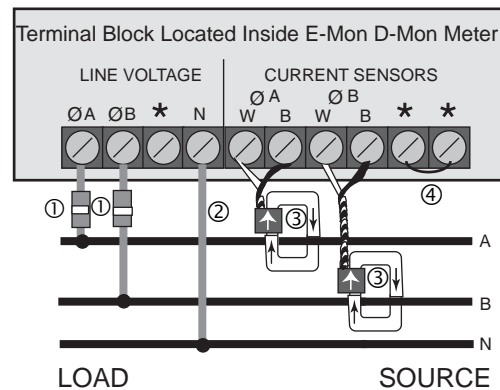

* These terminals are not used in Class 1000 installations.

- ① Recommended fuses or circuit breaker per the National Electrical Code (Meter load 6VA.)
- *② Neutral not used in delta system.
- ③ Split-core current sensors. Install according to instructions.
- ④ Install jumper wire.

Typical Fuses: Littlefuse KLDR.100 (100 mA) Not included. (Consult local electrical codes for requirements.)

Stand-Alone Enclosure Specifications

Reference Guide

JIC Steel Enclosures-Small

Standard Enclosure for: Class 1000, 2000 and Green Class Meters
Optional for Class 3200 & Class 5000 Meters

Exterior Finish: Gray for all meters except Green Class Meter
(Green Class meter provided in Green enclosure)
Exterior Dimensions: 6" H x 6" W x 3" D
Mounting Flange Dimensions: 4" between holes Left/Right, 6.75" between holes Top/Bottom



JIC Steel Enclosure-Large

Standard Enclosure for: IDR
Optional for Class 3400 Meters

Exterior Finish: Gray
Exterior Dimensions: 8" H x 6" W x 4.36" D
Mounting Flange Dimensions: 4" between holes Left/Right, 8.75" between holes Top/Bottom



NEMA 4X Outdoor Enclosure-Small

Standard Enclosure for: Class 3200 & 5000 Meters
Optional for Class 1000, 2000 & Green Class Meters

Exterior Finish: Gray
Exterior Dimensions: 6.54" H x 6.54" W x 4" D
Mounting Flange Dimensions: 4" between holes Left/Right, 6.75" between holes Top/Bottom



NEMA 4X Outdoor Enclosure-Large

Standard Enclosure for: Class 3400 Meters

Exterior Finish: Gray
Exterior Dimensions: 6.54" W x 8.54" H x 4" D
Mounting Flange Dimensions: 4" between holes Left/Right, 8.75" between holes Top/Bottom



Non-Metallic DIN-Rail Enclosure

Standard Enclosure for: Din-Mon Meters

Exterior Finish: Gray
Exterior Dimensions: 5.5" H x 4.3" W x 2.3" D
Mounting: Standard DIN-Rail Mounting Configuration



MMU Multiple Meter Unit Enclosure Specifications

Reference Guide



Features

- Available in configurations containing up to 8, 16 or 24 meters.
- MMU cabinets may contain E-Mon D-Mon Class 1000, Class 2000 (kWh or kWh/Demand), Green Class and/or Class 3200 meters.
- Compact installation of multiple meters allow for easy and centralized reading.
- IDRs (Interval Data Recorders) can be factory installed inside the MMU enclosures along with the meters allowing for easy interface to the E-Mon Energy software system. (IDRs are mounted on back wall of the enclosure).
- Three-phase MMU cabinets with Class 2000, 3200 or green meters are shipped with prewired voltage feeds. If IDR(s) are installed inside the MMU cabinets, the connections from the meters to the IDRs are also prewired at the factory.
- MMU cabinets may contain meters of different voltage configurations. (i.e. 208V & 480V meters inside a single MMU enclosure.)

Note: All voltages being monitored must be provided to MMU cabinet.

MMU Models

MMU Cabinet Sizes

MMU8
MMU16
MMU24

When ordering, specify configuration, meters to be contained inside cabinet, and blank spaces (if any).

Example:

1 MMU8
6 E20-208200-MKIT
1 E20-480200-MKIT
1 Blank Space

MMU Dimensions

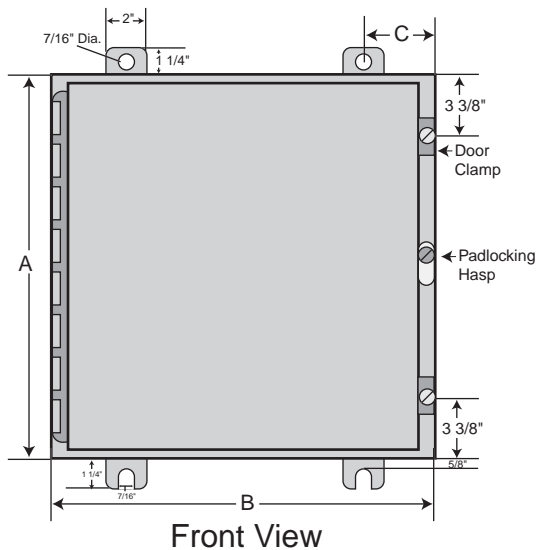

Side View

MMU	Dimensions (in inches)		
	A	B	C
MMU8	24	12	1 1/4
MMU16	24	20	3
MMU24	30	24	3

MMU	Meter Configuration		Total Meter Spaces
	Across	Down	
MMU8	2	4	8
MMU16	4	4	16
MMU24	5	5	24

The table below represents a sampling of the Modbus data points available from E-Mon D-Mon meters and IDRs. Visit www.emon.com for specific information for each product.

Address	Registers	Format	Description	Units	CL3200 Din-Mon	CL3400 CL5000	Notes
40001	2	Integer	Energy delivered	Wh Pulse	R/W	R/W	1
40003	2	Integer	Energy received	Wh Pulse	R/W	R/W	1
40005	2	Integer	Reactive energy delivered	VARh Pulse	R/W	R/W	1
40007	2	Integer	Reactive energy received	VARh Pulse	R/W	R/W	1
41001	2	Float	Energy delivered	kWh	R/W	R/W	1
41003	2	Float	Energy received	kWh	R/W	R/W	1
41005	2	Float	Reactive energy delivered	kVARh	R/W	R/W	1
41007	2	Float	Reactive energy received	kVARh	R/W	R/W	1
41009	2	Float	Real power	kW	R	R	
41011	2	Float	Reactive power	kVAR	R	R	
41013	2	Float	Apparent power	kVA	R	R	
41015	2	Float	Power factor	% PF	R	R	
41017	2	Float	Peak demand	kW	R/W	R/W	
41019	2	Float	Current average	Amps	R	R	
41021	2	Float	Voltage line-neutral	Volts-N	R	R	
41023	2	Float	Voltage line-line	Volts-L	R	R	
41025	2	Float	Frequency	Hz	R	R	
41027	2	Float	Phase angle	Degree	R	R	
41029	2	Float	Real power, phase A	kW	R	R	
41031	2	Float	Real power, phase B	kW	R	R	
41033	2	Float	Real power, phase C	kW	R	R	
41035	2	Float	Reactive power, phase A	kVAR	R	R	
41037	2	Float	Reactive power, phase B	kVAR	R	R	
41039	2	Float	Reactive power, phase C	kVAR	R	R	
41041	2	Float	Apparent power, phase A	kVA	R	R	
41043	2	Float	Apparent power, phase B	kVA	R	R	
41045	2	Float	Apparent power, phase C	kVA	R	R	
41047	2	Float	Power factor, phase A	% PF	R	R	
41049	2	Float	Power factor, phase B	% PF	R	R	
41051	2	Float	Power factor, phase C	% PF	R	R	
41053	2	Float	Current, phase A	Amps	R	R	
41055	2	Float	Current, phase B	Amps	R	R	
41057	2	Float	Current, phase C	Amps	R	R	
41059	2	Float	Voltage, line to neutral, phase A-N	Volts-N	R	R	
41061	2	Float	Voltage, line to neutral, phase B-N	Volts-N	R	R	
41063	2	Float	Voltage, line to neutral, phase C-N	Volts-N	R	R	
41065	2	Float	Voltage, line to line, phase A-B	Volts-L	R	R	
41067	2	Float	Voltage, line to line, phase B-C	Volts-L	R	R	
41069	2	Float	Voltage, line to line, phase C-A	Volts-L	R	R	
41071	2	Float	Phase angle, phase A	Degree	R	R	
41073	2	Float	Phase angle, phase B	Degree	R	R	
41075	2	Float	Phase angle, phase C	Degree	R	R	
41083	2	Float	External Input 1	Pulse		R/W	2
41085	2	Float	External Input 2	Pulse		R/W	2
44001	6	Custom	Interval Day Block		R/W	R/W	3
44007	1 per interval	Integer	Interval Data	Pulse	R	R	4
45501	2 per day	Custom	Interval Data Headers		R	R	5
46025	8	Custom	RTC Date/Time		R/W	R/W	6
46049	8	Custom	EZ7 ID, ModBus ID, Serial Number		R/W	R/W	7
46057	8	Custom	Recorder Info., Demand Interval		R/W	R/W	
46513	8	Custom	Flags L1: Power Failure, Battery		R	R	
46521	8	Custom	Flags L2: Power Failure Date		R	R	

BACnet Object Descriptor Sample

Reference Guide

The table below represents a sampling of the BACnet object descriptors available from E-Mon D-Mon meters and IDRs. Visit www.emon.com for specific information for each product.

Instance ID	BACnet Object	Description	Units	BACnet Property	CL3200 Din-Mon	CL3400 CL5000	Notes
1	Analog Input	Energy delivered	kWh	Present Value	R	R	1
2	Analog Input	Energy received	kWh	Present Value	R	R	1
3	Analog Input	Reactive energy delivered	kVARh	Present Value	R	R	1
4	Analog Input	Reactive energy received	kVARh	Present Value	R	R	1
5	Analog Input	Real power	kW	Present Value	R	R	
6	Analog Input	Reactive power	kVAR	Present Value	R	R	
7	Analog Input	Apparent power	kVA	Present Value	R	R	
8	Analog Input	Power factor	% PF	Present Value	R	R	
9	Analog Input	Peak demand	kW	Present Value	R	R	
10	Analog Input	Current average	Amps	Present Value	R	R	
11	Analog Input	Voltage line-neutral	Volts-N	Present Value	R	R	
12	Analog Input	Voltage line-line	Volts-L	Present Value	R	R	
13	Analog Input	Frequency	Hz	Present Value	R	R	
14	Analog Input	Phase angle	Degree	Present Value	R	R	
15	Analog Input	Real power phase A	kW	Present Value	R	R	
16	Analog Input	Real power phase B	kW	Present Value	R	R	
17	Analog Input	Real power phase C	kW	Present Value	R	R	
18	Analog Input	Reactive power phase A	kVAR	Present Value	R	R	
19	Analog Input	Reactive power phase B	kVAR	Present Value	R	R	
20	Analog Input	Reactive power phase C	kVAR	Present Value	R	R	
21	Analog Input	Apparent power phase A	kVA	Present Value	R	R	
22	Analog Input	Apparent power phase B	kVA	Present Value	R	R	
23	Analog Input	Apparent power phase C	kVA	Present Value	R	R	
24	Analog Input	Power factor phase A	% PF	Present Value	R	R	
25	Analog Input	Power factor phase B	% PF	Present Value	R	R	
26	Analog Input	Power factor phase C	% PF	Present Value	R	R	
27	Analog Input	Current phase A	Amps	Present Value	R	R	
28	Analog Input	Current phase B	Amps	Present Value	R	R	
29	Analog Input	Current phase C	Amps	Present Value	R	R	
30	Analog Input	Voltage line-neutral phase A-N	Volts-N	Present Value	R	R	
31	Analog Input	Voltage line-neutral phase B-N	Volts-N	Present Value	R	R	
32	Analog Input	Voltage line-neutral phase C-N	Volts-N	Present Value	R	R	
33	Analog Input	Voltage line-line phase A-B	Volts-L	Present Value	R	R	
34	Analog Input	Voltage line-line phase B-C	Volts-L	Present Value	R	R	
35	Analog Input	Voltage line-line phase C-A	Volts-L	Present Value	R	R	
36	Analog Input	Phase angle phase A	Degree	Present Value	R	R	
37	Analog Input	Phase angle phase B	Degree	Present Value	R	R	
38	Analog Input	Phase angle phase C	Degree	Present Value	R	R	
39	Analog Input	Reserve A	No units	Present Value	R	R	
40	Analog Input	Reserve B	No units	Present Value	R	R	
41	Analog Input	Reserve C	No units	Present Value	R	R	
42	Analog Input	External Input 1	Pulse	Present Value		R	2
43	Analog Input	External Input 2	Pulse	Present Value		R	2

1. To clear single meter kWh/kVARh, select reset kW/kWh on the display menu of the meter. This function will also reset external inputs. Jumper J6 must be closed.
2. External inputs are standard on Class 5000 meters and optional on Class 3400 meters (Part of Expanded Feature Package). To clear external inputs, select reset kW/kWh on the display menu of the meter. This function will also reset kW/kVARh. Jumper J6 must be closed.

Instance ID	BACnet Object	BACnet Property	CL3200 Din-Mon	CL3400 CL5000	Notes
BACnet Device ID	Device	Object identifier	R	R	
BACnet Device ID	Device	Object name	R	R	
BACnet Device ID	Device	Object type	R	R	
BACnet Device ID	Device	System status	R/W	R/W	
BACnet Device ID	Device	Vendor name	R	R	
BACnet Device ID	Device	Vendor Identifier	R	R	
BACnet Device ID	Device	Model name	R	R	
BACnet Device ID	Device	Firmware revision	R	R	
BACnet Device ID	Device	Application software version	R	R	
BACnet Device ID	Device	Location	R/W	R/W	
BACnet Device ID	Device	Description	R/W	R/W	

The table below represents a sampling of the BACnet PIC Statement available from E-Mon D-Mon meters and IDRs. Visit www.emon.com for specific information for each product.

PIC STATEMENT for Class 3200, 3400, 5000, Din-Mon Meters & IDRs

BACNET PROTOCOL IMPLEMENTATION CONFORMANCE STATEMENT

Date: October 2013
Vendor Name: E-Mon
Vendor ID: 482
Product Name: Class 3200 Meter, Class 3400 Meter, Class 5000 Meter, Din-Mon Meter, IDR
Product Model Numbers: E32-208100-RBACKIT, E34-480200-R05KIT, E50-480200-R03KIT, E-D5-480100-S12SPL3-V3KIT3, EIDR-8-R05RJ
Product Description: This product will provide bi-directional communication between E-Mon BACnet MS/TP meters, BACnet IP meters, and a BACnet system.

BACnet Standardized Device Profile (Annex L):

BACnet Smart Sensor (B-SS)

BACnet Interoperability Building Blocks Supported (Annex K):

- K.1.2 BIBB - Data Sharing - ReadProperty-B (DS-RP-B)
- K.1.4 BIBB - Data Sharing - ReadPropertyMultiple-B (DS-RPM-B)
- K.5.2 BIBB - Device Management - Dynamic Device Binding-B (DM-DDB-B)
- K.5.4 BIBB - Device Management - Dynamic Object Binding-B (DM-DOB-B)
- K.5.12 BIBB – Device Management – TimeSynchronization-B (DM-TS-B)

Segmentation Capability:

None

Standard Object Types Supported:

- Device Object
- Analog Input

For all these properties the following apply:

1. Does not support BACnet CreateObject
2. Does not support BACnet DeleteObject
3. No additional writeable properties exist
4. No proprietary properties exist
5. No range restrictions exist

Data Link Layer Options:

- MS/TP master (Clause 9), baud rate(s): 9.6k, 19.2k, 38.4k, 76.8k bps
- BACnet IP, (Annex J): Class 3200 meter does not support BACnet IP

Static Device Address Binding:

Not supported

Character Sets Supported:

- ANSI X3.4

Reference Guide

The table below represents a sampling of the LonWorks SNVTs available from E-Mon D-Mon meters and IDRs. Visit www.emon.com for specific information for each product.

Network Variable Name	Function Block Index	Network Variable Index	SNVT Type	Description	Units	CL3400 CL5000	
						Din-Mon	Notes
nvoWh_DelPulse	1	3	SNVT_count_32	Energy delivered pulse	Wh pulse	R	1
nvoWh_RecPulse	2	4	SNVT_count_32	Energy received pulse	Wh pulse	R	1
nvoVARh_RecPulse	3	5	SNVT_count_32	Reactive energy delivered pulse	VARh pulse	R	1
nvoVARh_DelPulse	4	6	SNVT_count_32	Reactive energy received pulse	VARh pulse	R	1
nvoKWh_Del	5	7	SNVT_count_inc_f	Energy delivered	kWh	R	1
nvoKWh_Rec	6	8	SNVT_count_inc_f	Energy received	kWh	R	1
nvoKVARh_Del	7	9	SNVT_count_inc_f	Reactive energy delivered	kVARh	R	1
nvoKVARh_Rec	8	10	SNVT_count_inc_f	Reactive energy received	kVARh	R	1
nvoReal_Pwr	9	11	SNVT_count_inc_f	Real power	kW	R	
nvoReact_Pwr	10	12	SNVT_count_inc_f	Reactive power	kVAR	R	
nvoAppar_Pwr	11	13	SNVT_count_inc_f	Apparent power	kVA	R	
nvoPwr_Fact	12	14	SNVT_pwr_fact_f	Power factor	% PF	R	
nvoPeak_Dem	13	15	SNVT_count_inc_f	Peak demand	kW	R	1
nvoCurrent_Avg	14	16	SNVT_amp_f	Current average	Amps	R	
nvoVolt_LN	15	17	SNVT_volt_f	Voltage line-neutral	Volts-N	R	
nvoVolt_LL	16	18	SNVT_volt_f	Voltage line-line	Volts-L	R	
nvoFrequency	17	19	SNVT_freq_f	Frequency	Hz	R	
nvoPhase_Angle	18	20	SNVT_count_inc_f	Phase angle	Degree	R	
nvoReal_Pwr_PhA	19	21	SNVT_count_inc_f	Real power, phase A	kW	R	
nvoReal_Pwr_PhB	20	22	SNVT_count_inc_f	Real power, phase B	kW	R	
nvoReal_Pwr_PhC	21	23	SNVT_count_inc_f	Real power, phase C	kW	R	
nvoReact_Pwr_PhA	22	24	SNVT_count_inc_f	Reactive power, phase A	kVAR	R	
nvoReact_Pwr_PhB	23	25	SNVT_count_inc_f	Reactive power, phase B	kVAR	R	
nvoReact_Pwr_PhC	24	26	SNVT_count_inc_f	Reactive power, phase C	kVAR	R	
nvoAppar_Pwr_PhA	25	27	SNVT_count_inc_f	Apparent power, phase A	kVA	R	
nvoAppar_Pwr_PhB	26	28	SNVT_count_inc_f	Apparent power, phase B	kVA	R	
nvoAppar_Pwr_PhC	27	29	SNVT_count_inc_f	Apparent power, phase C	kVA	R	
nvoPwr_Fact_PhA	28	30	SNVT_pwr_fact_f	Power factor, phase A	% PF	R	
nvoPwr_Fact_PhB	29	31	SNVT_pwr_fact_f	Power factor, phase B	% PF	R	
nvoPwr_Fact_PhC	30	32	SNVT_pwr_fact_f	Power factor, phase C	% PF	R	
nvoCurrent_PhA	31	33	SNVT_amp_f	Current, phase A	Amps	R	
nvoCurrent_PhB	32	34	SNVT_amp_f	Current, phase B	Amps	R	
nvoCurrent_PhC	33	35	SNVT_amp_f	Current, phase C	Amps	R	
nvoVolt_LN_PhA_N	34	36	SNVT_volt_f	Voltage, line to neutral, phase A-N	Volts-N	R	
nvoVolt_LN_PhB_N	35	37	SNVT_volt_f	Voltage, line to neutral, phase B-N	Volts-N	R	
nvoVolt_LN_PhC_N	36	38	SNVT_volt_f	Voltage, line to neutral, phase C-N	Volts-N	R	
nvoVolt_LL_PhA_B	37	39	SNVT_volt_f	Voltage, line to line, phase A-B	Volts-L	R	
nvoVolt_LL_PhB_C	38	40	SNVT_volt_f	Voltage, line to line, phase B-C	Volts-L	R	
nvoVolt_LL_PhC_A	39	41	SNVT_volt_f	Voltage, line to line, phase C-A	Volts-L	R	
nvoPhase_AngleA	40	42	SNVT_count_inc_f	Phase angle, phase A	Degree	R	
nvoPhase_AngleB	41	43	SNVT_count_inc_f	Phase angle, phase B	Degree	R	
nvoPhase_AngleC	42	44	SNVT_count_inc_f	Phase angle, phase C	Degree	R	
nvoReserve_A	43	45	SNVT_count_f	Reserve A	No units	R	
nvoReserve_B	44	46	SNVT_count_f	Reserve B	No units	R	
nvoReserve_C	45	47	SNVT_count_f	Reserve C	No units	R	
nvoExt_Input_1	46	48	SNVT_count_f	External Input 1	Pulse	R	1
nvoExt_Input_2	47	49	SNVT_count_f	External Input 2	Pulse	R	1
nviResetUsageCh	48	50	SNVT_count	Reset Usage Channel	Integer Channel	R/W	1
nviRTC_DateTime	49	51	SNVT_time_stamp	RTC Date, Time Read	Date, Time	R/W	2
nvoRTC_DateTime	49	52	SNVT_time_stamp	RTC Date, Time Set	Date, Time	R	2
nvoIntervalData	50	53	SNVT_reg_val_ts	Interval Data Pulse Read	Integer Pulses, Date, Time	R	3
nviIntDateTime	50	54	SNVT_time_stamp	Interval Date, Time Set	Date, Time	R/W	3
nviIntDataChan	50	55	SNVT_count	Interval Data Channel Set	Integer Channel	R/W	3
nviIntDataPeriod	50	56	SNVT_count	Interval Data Window Set	Minutes	R/W	3
nvoIntDataChan	50	57	SNVT_count	Interval Data Channel	Integer Channel	R	3
nvoStatus	0	0	SNVT_obj_status	Function Block Status	Function Block Status	R	4

E-Mon D-Mon[®]

The Industry's Choice For Submetering For Over 30 Years.

Installs Easily In Minutes!

Step 1: Mount the E-Mon D-Mon Meter.



Step 2: Install E-Mon's split-core current sensors around wire(s) to be monitored.

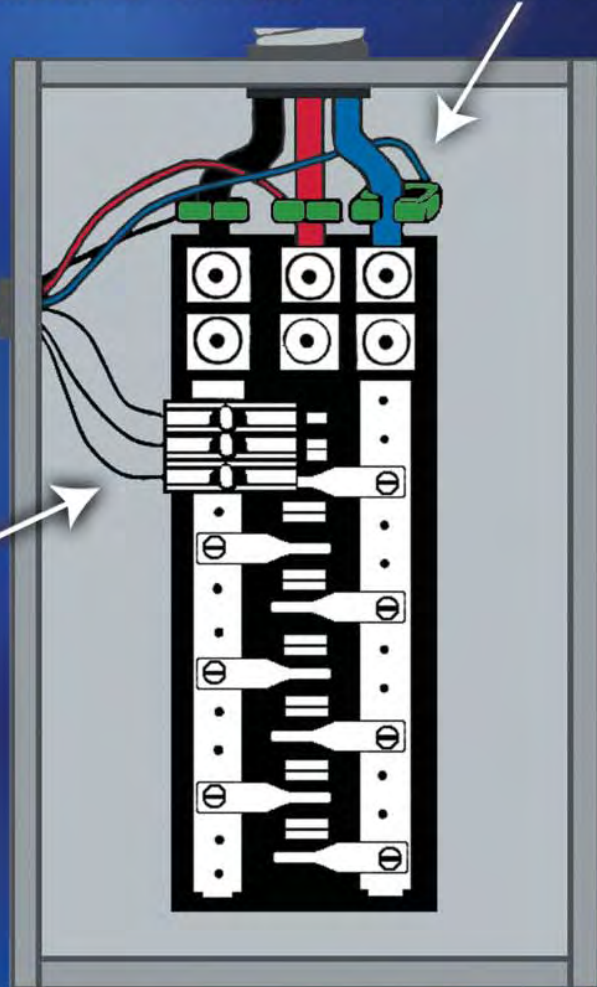

Step 3: Connect voltage wires.

E-Mon[®]

Energy Monitoring Products

(800) 334-3666
info@emon.com
www.emon.com

